

THE LIBRARY
DEC 10 1925
LIBRARY

Radio in the Home

Conducted by
HENRY M. NEELY

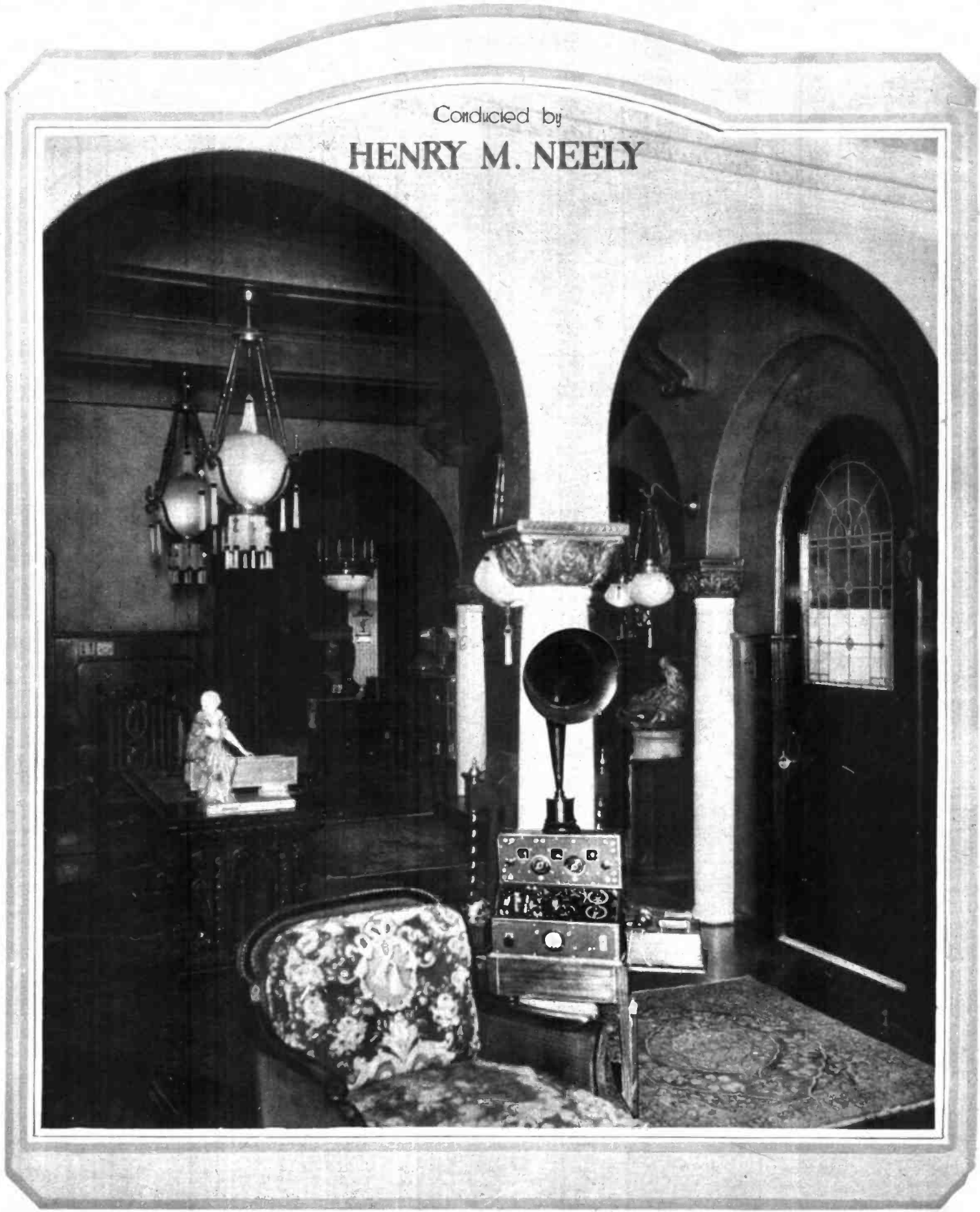

November, 1923

Radio in the Home of W. G. Whittaker, of Elkins Park, Pennsylvania
Photo by Harry S. Hood

Twentv Cents

ONE OF THE
GERACO
 TRADE MARK RADIO PRODUCTS

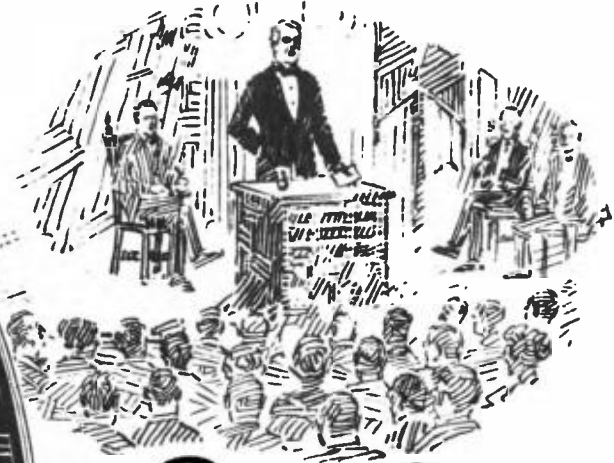
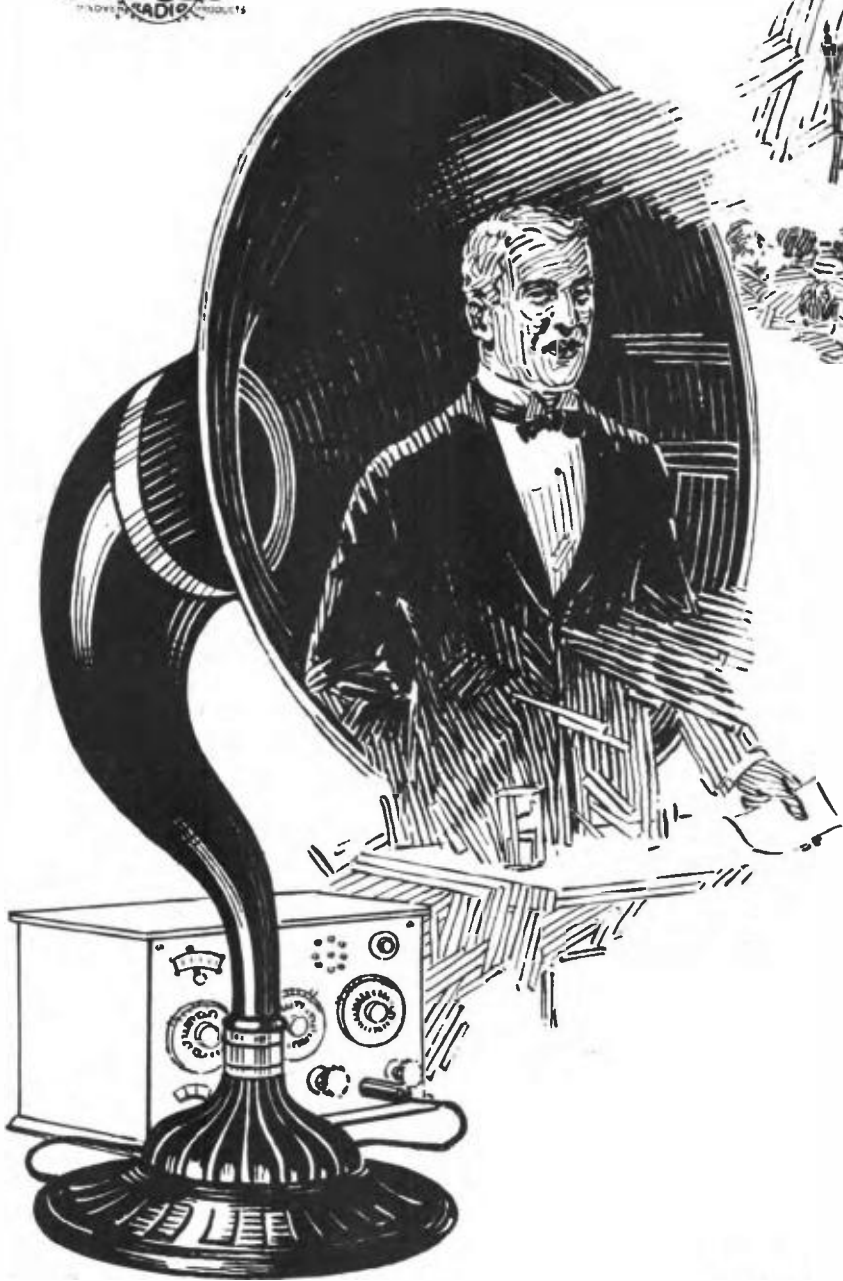

**So far—
 yet so
 near!**

The Mayor—the Senator—the Governor
 —the President—or other prominent speaker.

Hear him in your own home as clearly
 and distinctly as he is heard by audiences,
 scores of cities away! With **MUSIC
 MASTER!**

Have the family pull up chairs and listen
 to discussions of national topics by leaders
 of the state and nation. Through **MUSIC
 MASTER**, the most *natural* of radio re-
 producers.

Attached to any good receiving set,
MUSIC MASTER completes the enjoyment
 of radio. It is the comfortable, the unselfish
 way to hear radio. Hear **MUSIC MASTER**,
 with its unrivaled *wood* horn, at your radio
 dealer's.

Dealers Everywhere

GENERAL RADIO CORPORATION

Makers and Distributors of High-Grade Radio Apparatus

CHICAGO

PHILADELPHIA

PITTSBURGH

S. W. Cor. 10th and Cherry Sts.

14" Horn for the Home—\$30

21" Horn for Concerts—\$35

**Music
 Master**
 RADIO REPRODUCER

RADIO IN THE HOME

VOLUME II

For November, 1923

NUMBER VI



Radio in the Home of W. G. Whittaker Cover

Further Views of Mr. Whittaker's Radio Page 3

Radio in the Home of Prominent Washingtonians Page 4

WEAF, an Experiment Page 5

The Super-Heterodyne Page 11

The New F.1a Three-Tube Circuit Page 12

A Two-Step Amplifier Unit Page 15

The Radio Kindergarten, Lesson II Page 16



This is the home of W. G. Whittaker, of Elkins Park, Pa., whose radio set is shown on the front cover. In the circle is shown another setting for his receiving apparatus in front of his fireplace. Photos by Harry S. Hood

The Little Marvel of Radio, the "N" Tube. Page 18

Editorially Speaking Page 20

The Woman's Club in Our Town Discovers Radio Page 22

A New Idea in Crystal Hook-Ups Page 25

WGAM Makes Its Debut Page 26

Radio Is Now a Billion-Dollar Business Page 29

The Gibbons With a Variocoupler. Page 32

Is the Radio Market Saturated? ... Page 34

PUBLISHED MONTHLY BY THE HENRY M. NEELY PUBLISHING COMPANY

608 Chestnut St., Philadelphia, Pa.
BELL TELEPHONE—LOMBARD 8431
Experimental Station (3XP), Dolanoo, N. J.

HENRY M. NEELY President and Editor
G. W. KRAFT Secretary and Treasurer
FRANKLIN N. SUPPLEE General Representative
NORMAN NEELY Art Editor
THEODORE F. VOLTEN Technical Assistant

Radio in the Home is sold at 20c per copy at all newsstands, radio shops and bookstores. Subscription in the United States and Canada \$2.00 per year.

Printed on the rotogravure presses of the Public Ledger, Philadelphia, Pa.
Copyright, 1923, by the Henry M. Neely Publishing Company
Entered as second-class matter May 26th, 1922, at the Postoffice, Philadelphia, Pennsylvania, under the act of March 3d, 1879.

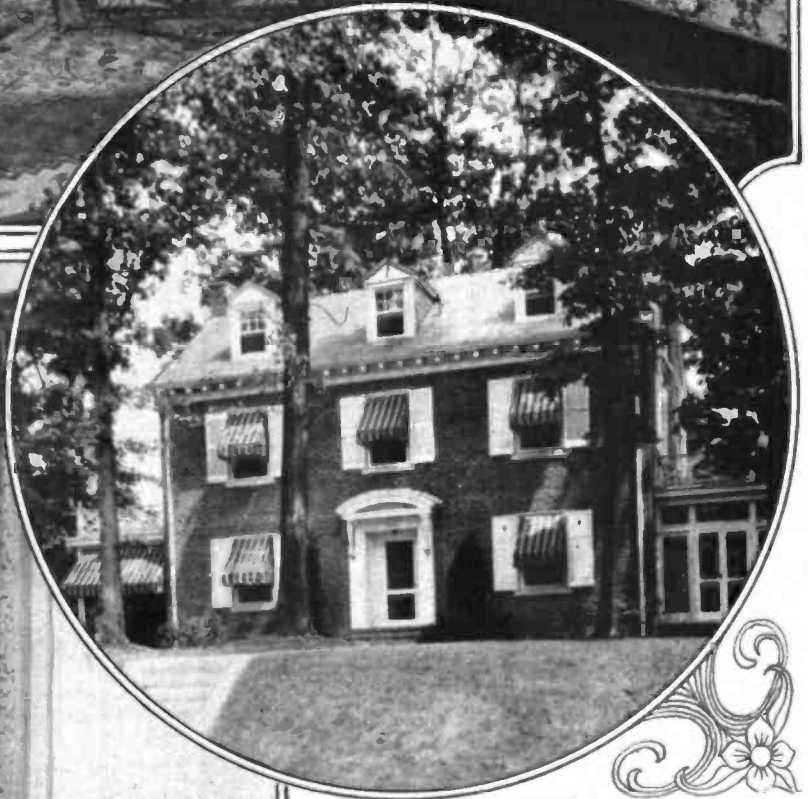
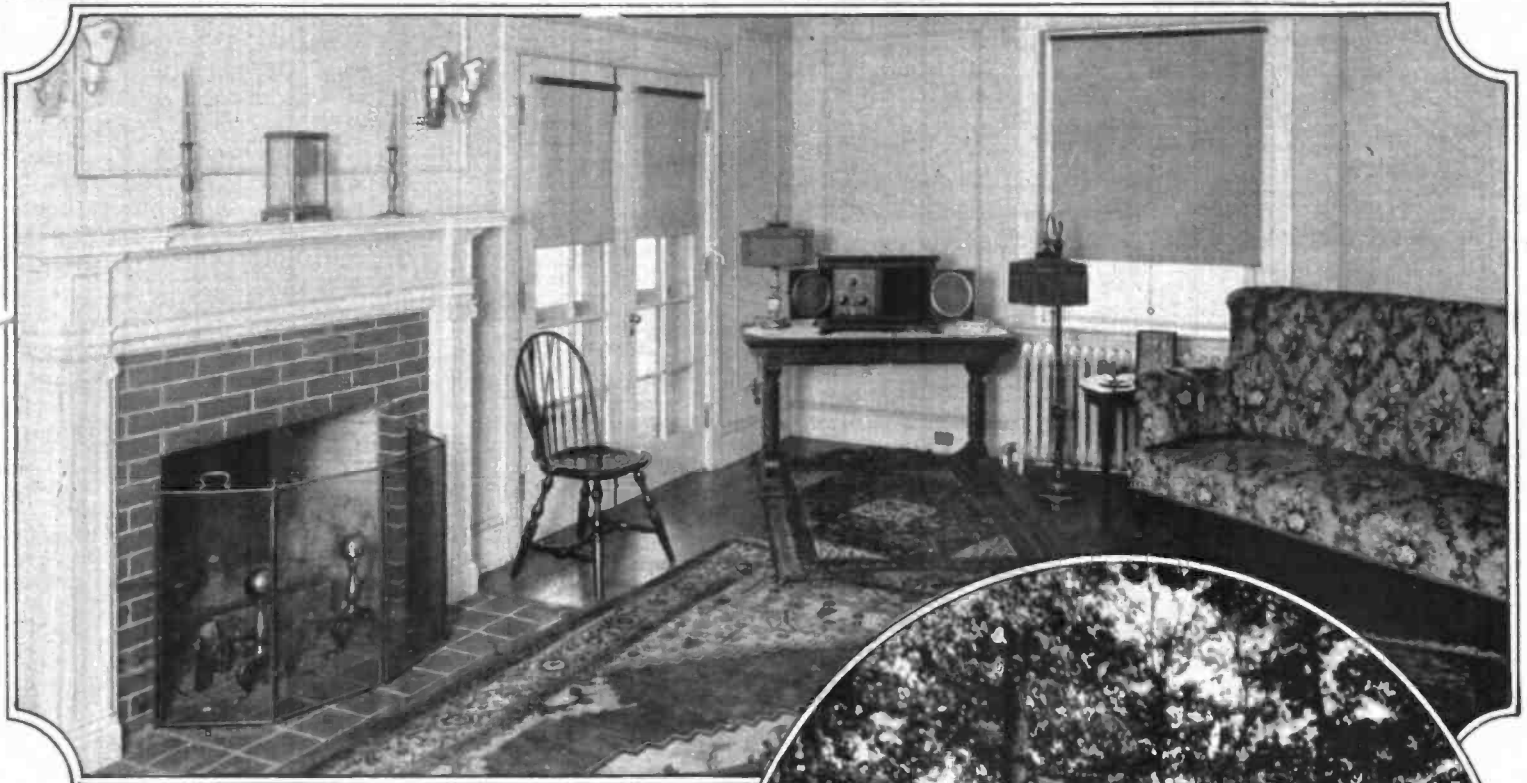

Above

Radio in the home of Philander C. Knox, son of the late Senator Philander C. Knox, of Pennsylvania; 3205 Cleveland Avenue, Washington, D. C.

Circle

View of Mr. Knox's beautiful residence

Left

Radio in the home of Judge S. B. Davis, solicitor Department of Commerce, 2226 Connecticut Avenue, Washington, D. C. Mrs. Davis and her daughter "listening-in"

Photos courtesy of the Radio Sales Studio, Inc., Washington, D. C.

WEAF

The most significant part of the work being done by WEAF is its investigation into the whole matter of radio broadcasting.

Users of radio sets must realize if they are business men, that broadcasting as it is done today—giving something for nothing—is not commercially nor economically a sound proposition. The radio craze will keep it going as it is for some time, but what is going to become of it after the craze dies down and radio becomes merely a form of home entertainment?

That is what WEAF is striving to find out.

I have been in communication for some time with Mr. W. E. Harkness, the manager of broadcasting, and Mr. E. H. Felix, assistant in charge of publicity, and the following article is culled from my correspondence with them and the information which they have sent me.—E. M. N.

THE fortunate radio listener who is able to hear the programs of most of the important stations of the country usually elects WEAF, of New York City, as his favorite station. But one who has had the opportunity to visit many broadcasting stations and to inspect critically their equipment and appointments, not only names WEAF a favorite but, without exaggeration, declares its broadcasting studios the finest in the country. From the standpoint of arrangement, equipment and appearance, they are entitled to recognized leadership.

WEAF is a large scale experiment being conducted by the American Telephone

(Continued on Page 36)

Two of the beautiful leaded glass doors in Station WEAF. Below: The magnificent reception room in which they are features. Other photographs of the station on the four following pages.

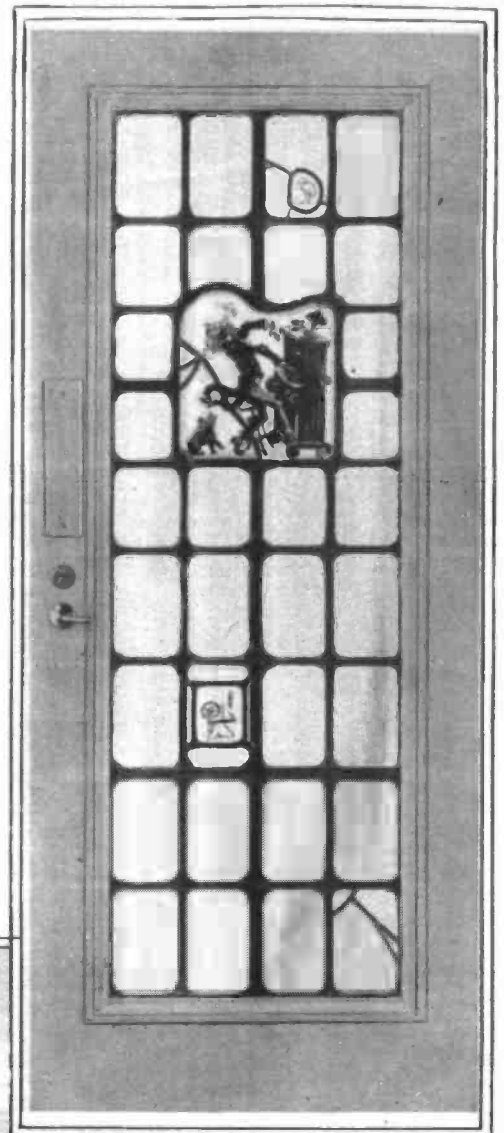
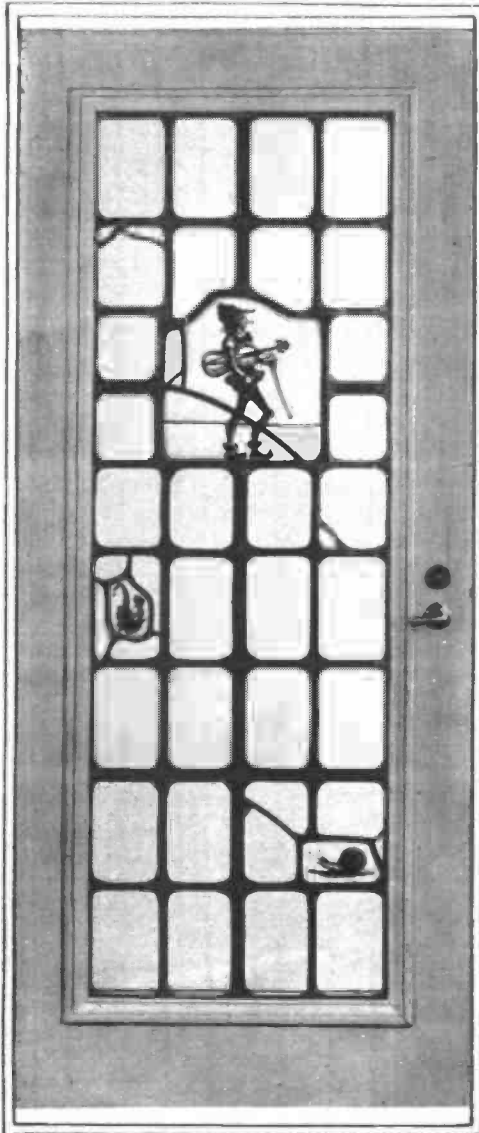



Above is the magnificent twenty thousand dollar tapestry which hangs on one wall of the reception room at WEAF. To the left is a view of the corner of this room showing the tapestry and also one of the doors, larger pictures of which appear on the preceding page.

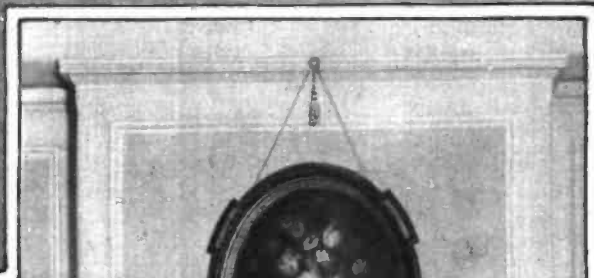
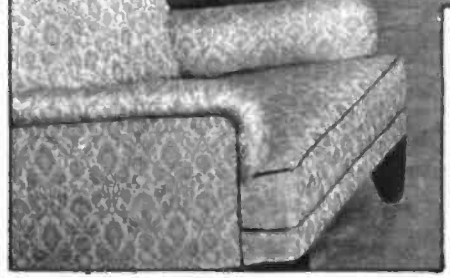
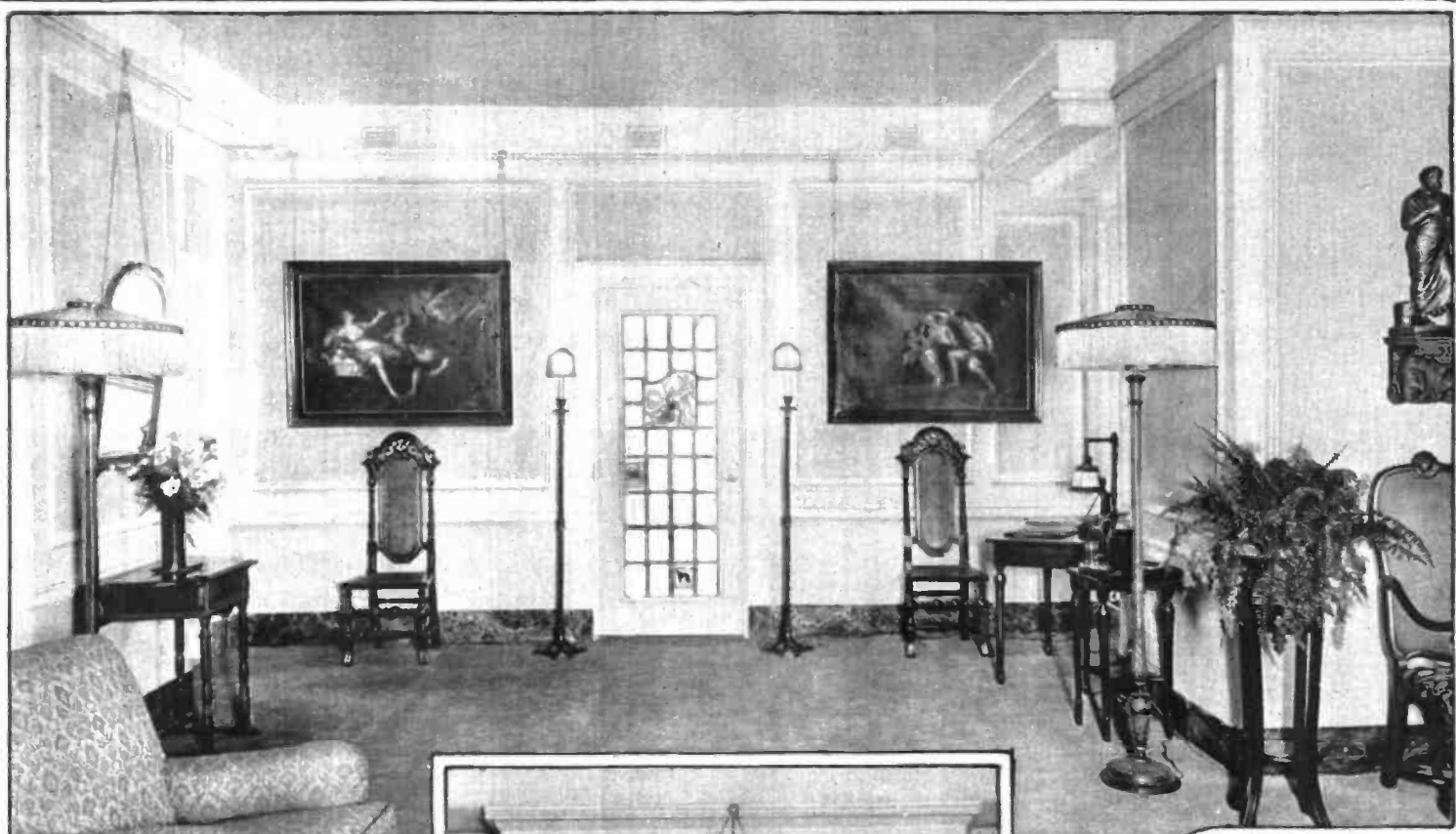

Above, one side of the reception room at WEA. Below, the fireplace in the reception room where visitors are received



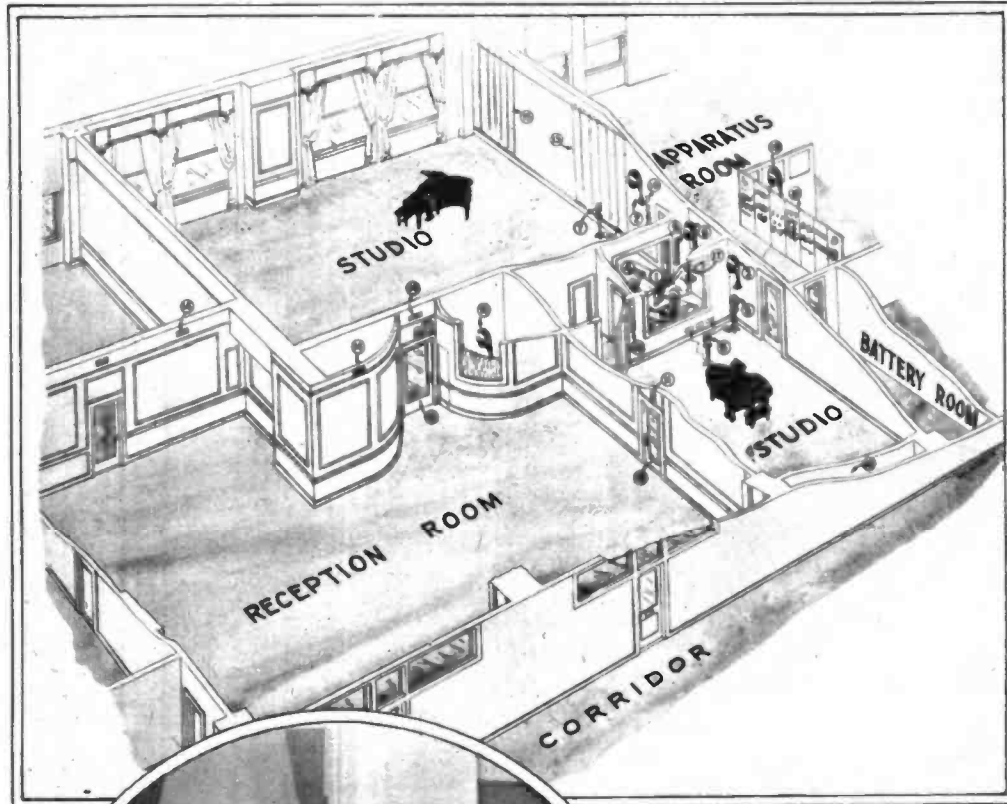
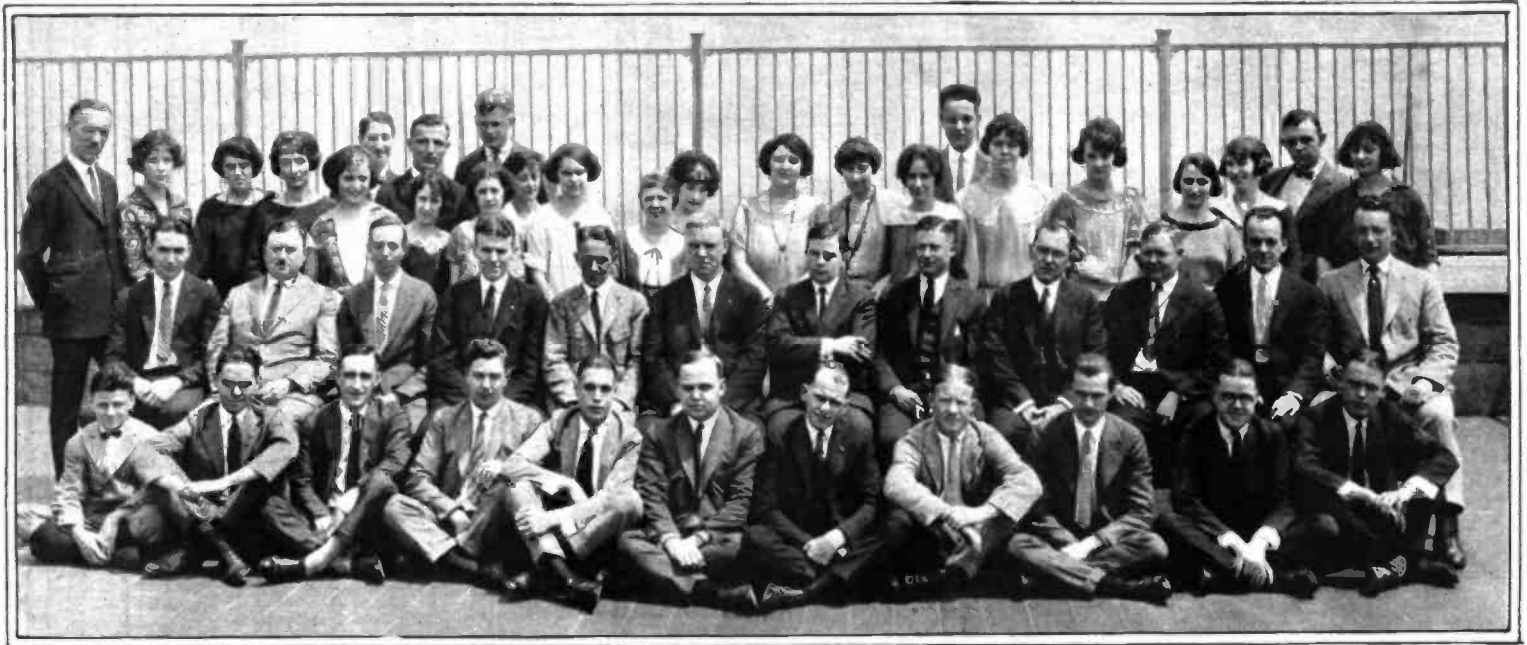

Above, the staff at W.E.A.F. Left, a view of W.E.A.F., showing the locations of the various rooms. The two studios can plainly be seen with the announcer's booth between them, giving him a view of both studios so that he can manage the program from his control station at his desk. Lower left and lower right, artists in the two studios at W.E.A.F.



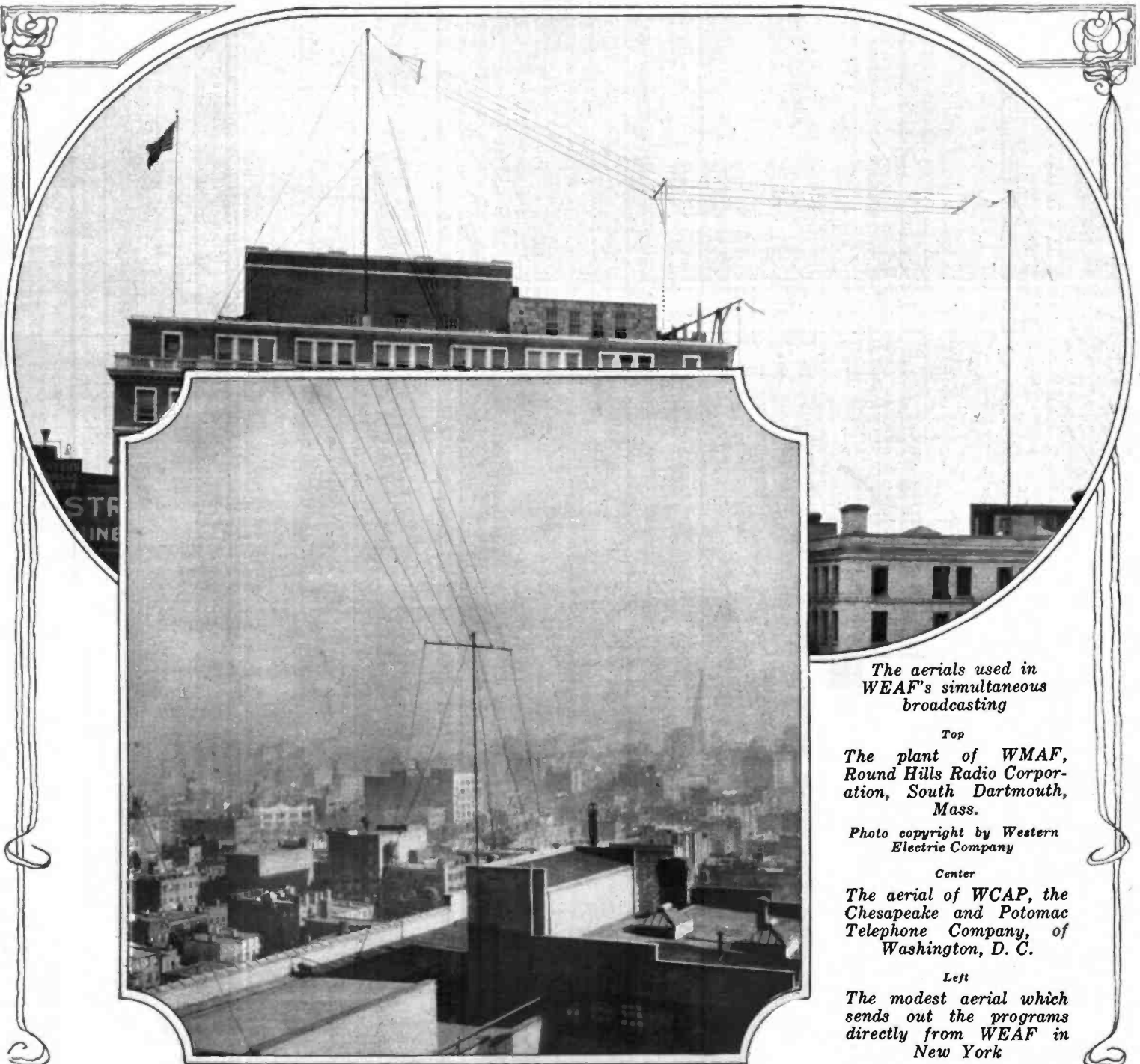
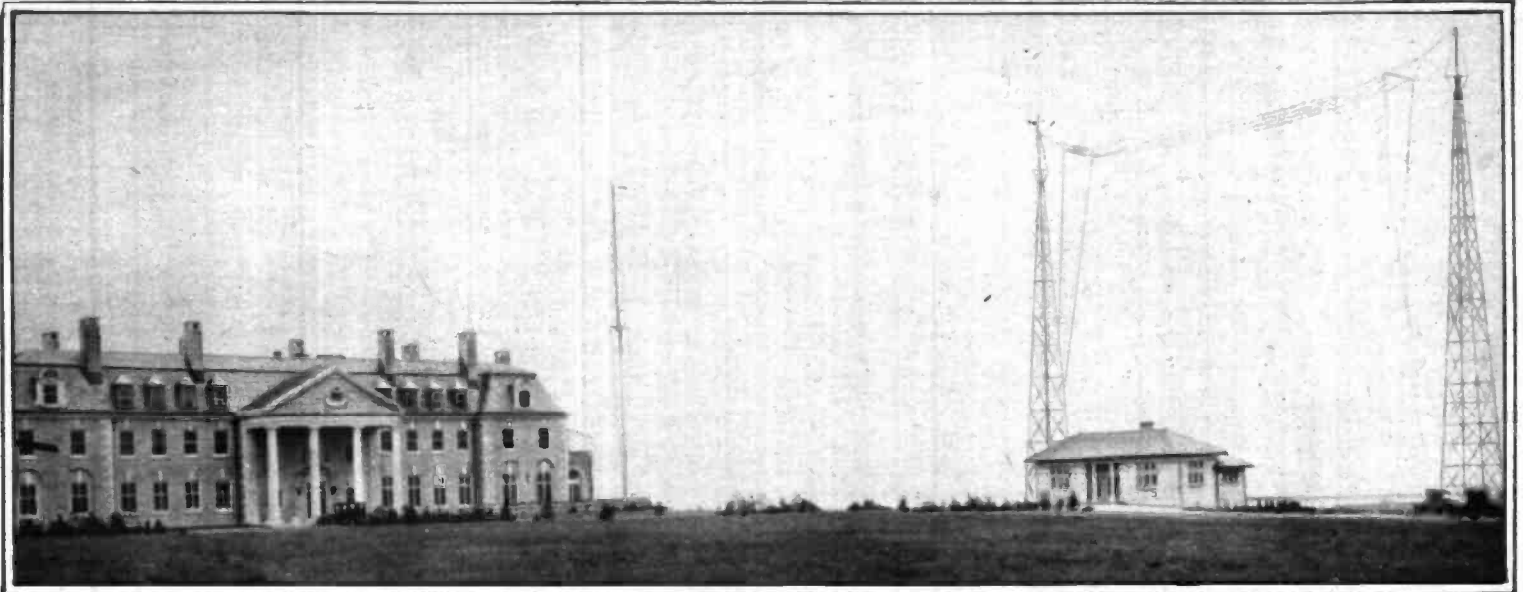

The aerials used in WEAf's simultaneous broadcasting

Top

The plant of WMAF, Round Hills Radio Corporation, South Dartmouth, Mass.

Photo copyright by Western Electric Company

Center

The aerial of WCAP, the Chesapeake and Potomac Telephone Company, of Washington, D. C.

Left

The modest aerial which sends out the programs directly from WEAf in New York



Super-heterodyne in the home of Birchall Hammer, Elkins Park, Pa. Mr. Hammer's home shows the combination which has been advocated in this magazine—the radio set, the piano and the Victrola. Mr. Hammer's article on the opposite page will answer the many questions which have been sent in about this famous circuit.
 Photos by Harry S. Hood

SUPER-HETERODYNE

By
BIRCHALL HAMMER

THE eight-tube super-heterodyne set which I assembled and am operating works on all wave lengths from 160 to 850 meters, and briefly the action is as follows:

Suppose the station desired is operating on 400 meters; the loop or antenna induction circuit is tuned to 400 meters by means of a wave length condenser, and the heterodyne condenser is operated to 30,000 cycles below or above 400 meters. This introduces a third component of 30,000 cycles (10,000 meters), which is an exact duplicate of the original signal, but at a different wave length.

At this high wave length the amplification can be carried on very efficiently. During this change a very high degree of selectivity is secured, due to the amplifier, which is designed to pass nothing but 30,000 cycles. Accordingly, while there may be ten or twenty strong signals on the air, only one can be heard at a time, the one that is heterodyned through the amplifier.

This set consists of so much that it is best to take up the separate units of the whole in their own operation, although all the units combined form the whole and operate as one.

The first is the antenna circuit, consisting of a tapped coil consisting of sixty-four turns on 3½-inch tube with a 43-plate condenser in series. Inside of this is a secondary inductance coil of sixty-five turns on 2½-inch tube, and this followed by a secondary loading inductance coil of seventy-seven turns on 3½-inch tube for wave lengths of 400 to 850 meters, as the primary and secondary inductance is only designed to carry 160 to 480 meters.

The leads are then forwarded to a double-pole double-throw jack which, when plugged in, throws off the antenna adapter circuit and operates the loop.

From this jack one wire runs to the grid of the first detector tube through a grid leak and condenser, the other wire running into the oscillating unit consisting of three coils set one inside the other, the inside coil consisting of twenty-one turns and the outside coil consisting of six turns, and as the primary and secondary coils of the antenna adapter are used for wave lengths of 160 to 480 meters, so also are these two coils used, while the inside coil is used for the higher wave lengths. This unit is supplied with an oscillating tube connected in this coil circuit.

The circuit then runs into a radio frequency coupler, being a set of coils consisting of two coils with 950 turns each, set one-eighth inch apart, both being shunted by condensers of .0025 capacity.

The next unit is the radio frequency circuit of three radio frequency transformers, No. UV1716, designed to receive only 5000 to 25,000 meter wave lengths, each operating tubes and volume controlled by a 400 ohm potentiometer shunted by a 1 mf condenser.

The next two units are a detector, the second in the set, and two stages of audio frequency amplification of low ratio to do away with distortion.

The set is jacked after the detector and also after each stage of audio frequency amplification.

There are only three controls, outside of the rheostats and the potentiometer. The first control is the 43-plate condenser in series with the aerial, the second control is a 43-plate condenser between the back of the inside coil of the heterodyne coils and the grid of the oscillating tube to the back of the outside coil and the front of the inside coils and from there through a condenser and coil into the plate of the oscillating tube. This is called the heterodyne condenser, and the third control is a special design .00027 condenser operating between the grid leak and condenser ahead of the first detector tube and the outside heterodyne coils, and which is called the wave length condenser.

For the rheostats, one is used for the oscillator tube, one for

DURING the past month or more I have been getting a great many letters asking me to give full details about the super-heterodyne circuit. I have purposely kept away from this circuit because it is rather more expensive than others. It requires a good many tubes, and is a little more complicated to wire up, but with the sudden increase in interest, I looked up a friend of mine who has been working one for some time and asked him about the results he was getting.

His report to me was so interesting that I asked him to put it in the form of a short article, so that I could answer all of the questions that have been asked me. The article appears on this page and I am also printing excerpts from the log of this station, showing the results that he obtained in summer time during what is ordinarily poor reception weather.

The friend who has written this article is Mr. Birchall Hammer, an officer of the Hammer Lumber Company, whose set is at his home, Elkins Park, Pa.

I am printing this article more as an answer to all of the questions that I have received than as a complete description of the super-heterodyne circuit. If there seems to be enough demand among my readers for this hook-up and a more explicit description of its details, I shall be very glad indeed to get together with Mr. Hammer, build one out at XEP and let you know how we constructed it and what results we have.

H. M. N.

the first detector tube, one for the second detector tube, and one which controls all three radio frequency and the two audio frequency tubes at the same time.

Great care must be exercised in wiring this set and it is important that standard parts be used as by the list shown below, which can be purchased at prices attached, which shows the cost of the set, exclusive of tubes, "B" batteries, "A" batteries, phones, cabinets, etc.

Antenna Adapter Unit

1 Panel 8x8	\$2.45
8 Panel Screws16
6' Empire Tubing66
6' Connecting Wire12
1 Dial and Knob, 4" Dial, 2½" Moulded Knob	1.50
4 Binding Posts, Gen. Rad. Co., Type 138X60
1 Wave Length Switch and Contacts, G. R. Type 139A	1.13
1 Antenna Induction Switch and Contacts, G. R. 139A	1.41
1 Variable Condenser, Gen. Radio Type 247	4.00

Super-Heterodyne Section Complete

1 Panel, 40x8x1¼", Black Formica	\$9.60
9 Binding Posts, Gen. Radio Type 138X	1.35
1 Variable Condenser, .00027 MF, E. I. S. Special	4.75
1 Variable Condenser, .001 MF, Gen. Radio Type 247B	4.00
Dials and Knobs, 2 Each, 4", Gen. Radio 137H	3.00
1 Wave Change Switch, Gen. Radio 139A	1.13
1 Potentiometer, 400 Ohms, Gen. Radio Type 214	3.00
3 Rheostats, 20 Ohms, Gen. Radio Type 214A	6.75
1 Rheostat, 7 Ohms, Gen. Radio Type 214A	2.25
8 Sockets, Gen. Radio Type 156	10.00
2 Audio Frequency Transformers, Gen. Radio 231A	10.00
3 Radio Frequency Transformers, Gen. Radio UV1716	25.50
2 Grid Leaks and Holders, Gen. Radio UP523 UX543	2.50
2 Grid Condensers, .00025 MF, Dubilier Type 60170
2 Radio Frequency Transformer Condensers, .0002570
1 By Pass Condenser, .001 MF, Dubilier Type 60140
2 By Pass Condensers, 1 MF, Western Elec. Type 21K	4.00
2 Closed Jacks, Premier Adjustable Type 131	1.90
1 Open Jack, Premier Adjustable Type 13365
1 Resistor, 48,000 Ohms., Western Elec. Type 38A	2.00
1 Condenser, .005 MF, Dubilier Type 600	1.00

The above does not include the wire, tubing, or screws, or the coils. It will take about 100 feet of wire to make the set, and the coils can be bought from the manufacturer as follows:

Primary Inductance Coil	\$2.60
Secondary Inductance Coil	1.25
Secondary Load Inductance	2.25
Radio Frequency Coupler, Complete	6.00
Oscillating Coupler	6.00

There should also be an ammeter and a voltmeter in this circuit, but the use of these is optional.

At the present time, I am using eight 201A tubes with 90 volts in "B" batteries and a 6 volt 110 amp. storage battery as an "A" battery.

Selectivity—The most selective set I have ever handled. When Washington, D. C., is operating at 403 meters and Havana is operating on 405 meters, with the loop pointing towards Washington it is very easy to cut off Washington and bring in Havana.

My set operates within nine miles of WOO, WIP, WFI and WDAR—all strong stations—and I can easily cut out any or all of them for long distance stations. In fact, KWH, Los Angeles, was received through WDAR only nine miles away and the meter length difference in the stations is very little.

Volume—With Magnavox on the porch, WOO was heard on the full capacity of the set to 2000 feet from the horn and WDAP, Chicago, 900 miles from the set, was heard on full capacity to 500 feet from the horn.

Range—There seems to be no limit to this set in good operation. In three weeks time I have heard 76 stations, one being on the Pacific Coast, and twenty-two of these being over 100 miles distant.

In winter I expect to be able to log every 500-watt station in

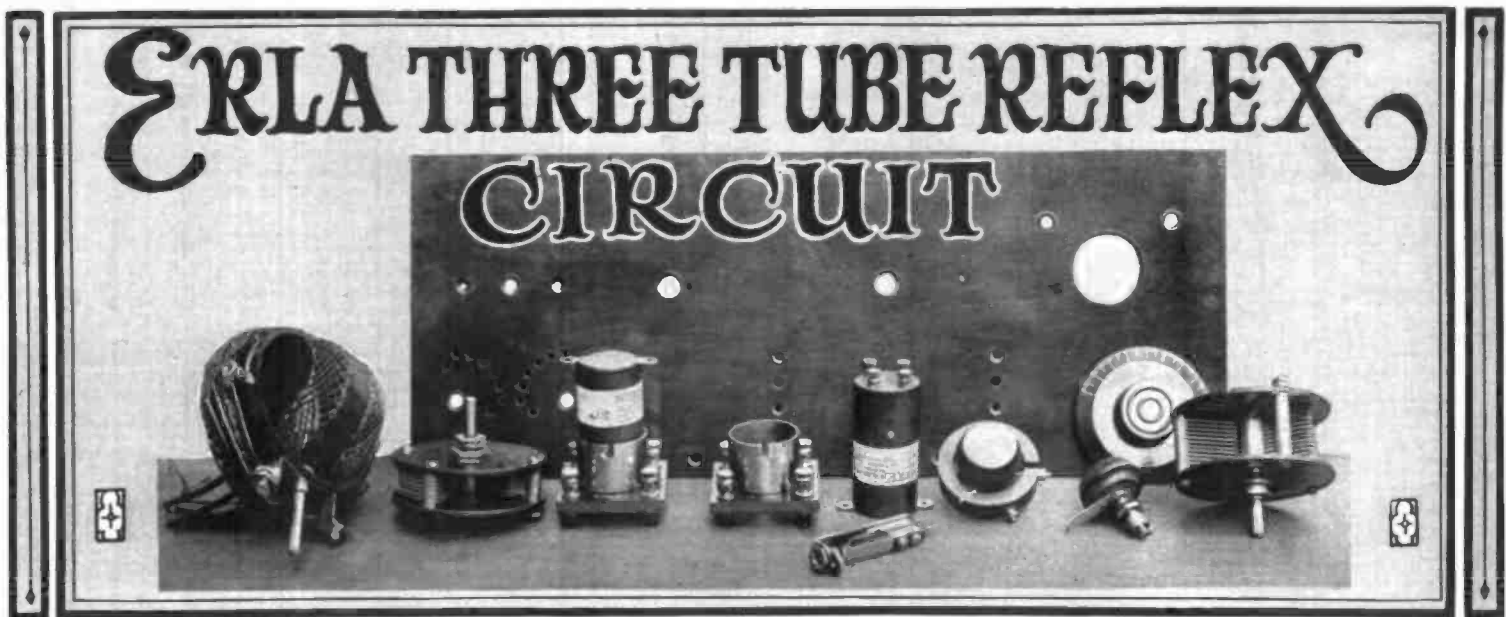

This is the layout of apparatus just as it is shipped to you from the factory

ABOUT six months ago the Electrical Research Laboratories of Chicago put out a new circuit which they called the Erla single-tube reflex. This circuit consisted of one tube which had a dual purpose. It was used first as a radio frequency amplifier; the set had a crystal detector and then used the same tube over again as an audio frequency amplifier.

This circuit took the country by storm. I believe that every state in the Union had the craze for building this Erla circuit. The circuit was, indeed, very good and we showed it in the July issue of *Radio in the Home*, and it has been everything that the Erla people—and we—claimed it to be.

Yet the Erla people were not satisfied with the results obtained from the one-tube Erla reflex circuit, and they naturally set themselves to work and have now devised a three-tube Erla reflex circuit with a crystal detector which is far superior in every way to their single-tube reflex.

In the first place the Erla people found that it was advisable to design a special reflex radio frequency transformer which gives the maximum amount of amplification for the three-tube Erla reflex circuit. This transformer has a different ratio of turns on the primary and secondary than the original transformer had. They call this new transformer the "reflex number two." This is used as the first stage of radio frequency amplification in their new three-tube circuit.

Naturally we had to build and show this circuit. We find that it is about the best reflex circuit that has been put out on

the market. It is very easy to adjust and it has no carrier waves nor whistles to disturb the reception of radio signals. The reflex transformers are designed in such a way as to cover a very broad band of wave lengths and tune remarkably sharp in this circuit. At Station 3XP we have had no difficulty in bringing in on a loud speaker such stations as Troy, N. Y.; Buffalo, N. Y.; New York City, Washington and other stations that were located within about five hundred miles of this station.

We are very much pleased with the operation of this circuit and the ease with which it is controlled. With ear phones we have brought in with wonderful volume stations like Omaha, Davenport and a great many others west of the Mississippi River.

Many of the radio frequency transformers that are on the market at the present time will oscillate over certain bands of wave length. Now an ideal radio frequency transformer is one that does not oscillate over the band of wave lengths

tory, as you have to control your regeneration, and to get maximum results from the radio frequency transformer you have to move your potentiometer so that the tubes are just on the point of oscillation. This gives you what they call "base regeneration," and that is where you get the maximum amount of signals.

The new Erla reflex transformers do not require a stabilizer or potentiometer. This is particularly true when the crystal detector is set, as the crystal tends to stop all of the oscillations in the previous tubes.

The new hookup is what we call a "two-circuit" tuner and has a primary coil and a secondary coil. This primary and secondary are in the variocoupler. The primary is tuned by the use of the switch taps and the secondary is tuned by the use of a 23-plate variable condenser.

After you have built this circuit and have completed wiring it you light the filaments of your tubes and with a pair of ear phones in the first jack, set the two

switches on the primary of the variocoupler so as to have in about three taps on one and two taps on the other. Move the rotor of the variocoupler to about 45 degrees. Then rotate the 23-plate variable condenser slowly between twenty and ninety degrees. At the same

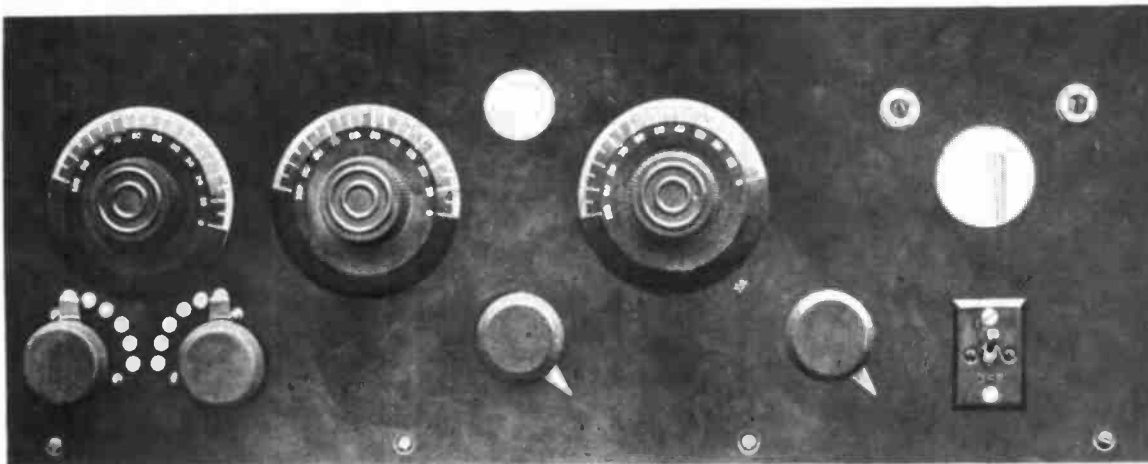

The new Erla circuit makes a very neat appearance when mounted upon a panel in this way

covered by broadcasting stations.

The transformers that do oscillate require a potentiometer to control these oscillations by either placing a positive or negative filament side on the grid of the tube.

The use of the potentiometer makes a radio frequency transformer less satisfac-

time you are rotating this, rotate the 11-plate variable condenser which is bridged across the primary of the first radio frequency transformer. Try to keep the numerals about the same as this.

If you have the 23-plate variable condenser at about thirty, try to keep the 11-

(Continued on Page 14)

Looking down from the back on the Erla three-tube reflex circuit

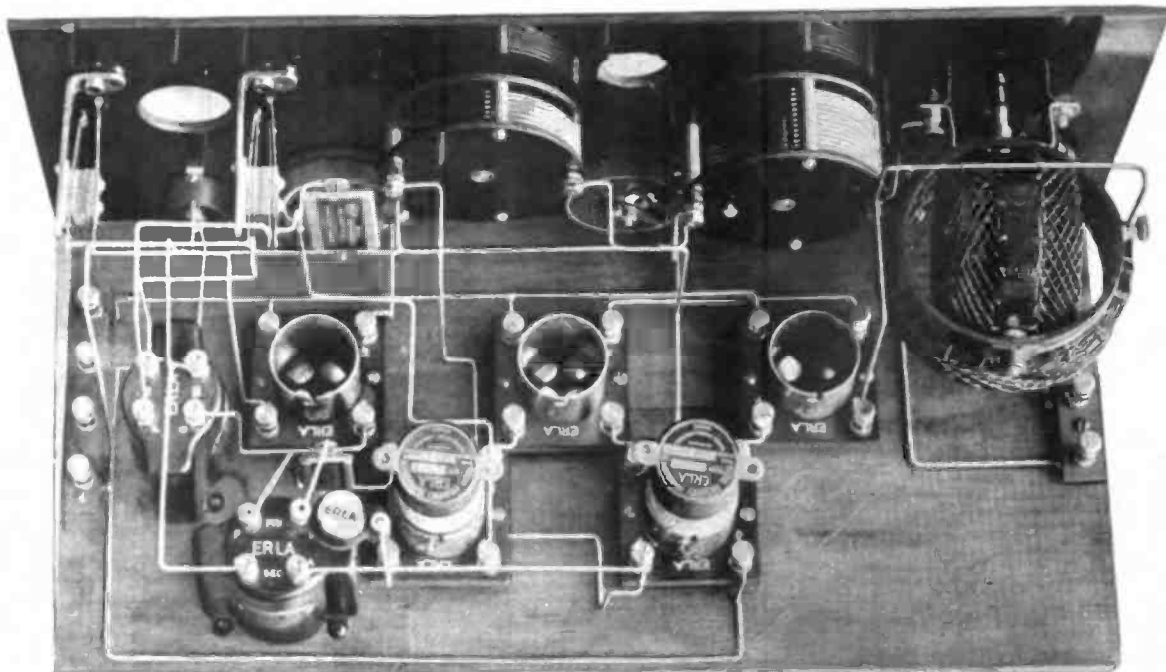

This shows the diamond-wound variocoupler and the layout of all the parts on panel and baseboard

(Continued From Page 12)

plate at about thirty and as you increase the 23-plate variable condenser increase the 11-plate over the entire range. If there is any concert on you will find that they will come in without a lot of whistles or howls.

You will pick up a station somewhere in turning these dials. After you have picked them up, just tune one at a time until you get to the maximum amount of signal. Sometimes this maximum amount will require the rotor coupling of the variocoupler to be either increased or decreased.

After you have the maximum amount of volume that you can get from tuning the variocoupler rotor and the two variable condensers, try increasing or decreasing the switch contacts. You will find that this will tune very sharp and the maximum results can easily be brought in.

After you have this on the first jack, then plug in your loud speaker on the second jack and retune very slightly the two variable condenser dials.

If, however, two stations happen to be very close in wave length, and you are having interference from one station when you are listening to another, this is the way to eliminate the undesirable station:

Move the variocoupler dial so as to have the rotor coil at about a right angle to the fixed coil. You will find as you move this rotor the signal will disappear entirely and this can be compensated for and brought back by slowly turning the dial of the 23-plate variable condenser. It will not be necessary for you to retune the 11-plate variable condenser, as this has already been tuned to the wave length of the station which you want to hear.

Of course, when you move the rotor of the variocoupler at a right angle to a fixed coil you also decrease slightly the volume of the circuit. This decreased volume, however, can really be appreciated when you know that you have a circuit that does not pick up a great deal of interference that you do not wish to listen to. The reduction of this signal strength is not sufficient to interfere with the clear reception that this circuit gives. As you tune, you will be surprised to find out that you are not bothered with a lot of body capacity

or tube noises or squeals or whistles, as you are with the regenerative circuits.

You really cannot tell when you first operate this circuit when you are coming to a station. You know that when you

have a regenerative circuit before you come to a station you get this peculiar whistle and that tells you that you are about on the wave length of a station.

With this new Erla reflex circuit, all these whistles are done away with and as you slowly move the dial the music just pops right out at you and then you move the two condenser dials slowly one way or the other to tune in the maximum signal strength.

When this maximum signal strength has been brought in, you can very easily make a "log" of the points of the variable condensers and the setting of the rotor and the switch settings. If you ever want to bring in this station again, all that is necessary is to set these dials and switch levers back to the original settings that you had before and you will find that you are right on the wave length.

This circuit is very sensitive. If properly controlled it is very selective and every one who builds it, I am sure, will appreciate it far more than they did the single-tube reflex which the Erla people published about six months ago.

The crystal detector which is mounted on the front of the panel shows how you can mount a crystal in use with this circuit. However, if you are using the Erla crystal, which is fixed permanently, it is not necessary for you to mount the crystal detector on the front of your panel. The Erla crystal is all inclosed and is mounted directly between the secondary post of the Erla reflex transformer to the primary post of the Erla audio frequency transformer.

The Erla crystal is entirely inclosed and dust-proof and is permanently fixed and never has to be changed. It is mounted very easily, as it has two wings out from each side to which the connections are made. If you look at the photograph you will see that the binding post of the audio frequency transformer goes directly through one of these wings of the Erla crystal. The other side of the Erla crystal has a wire run down to the radio reflex transformer circuit.

You can, however, use any good crystal. The last time we gave a reflex hook-

(Continued on Page 37)

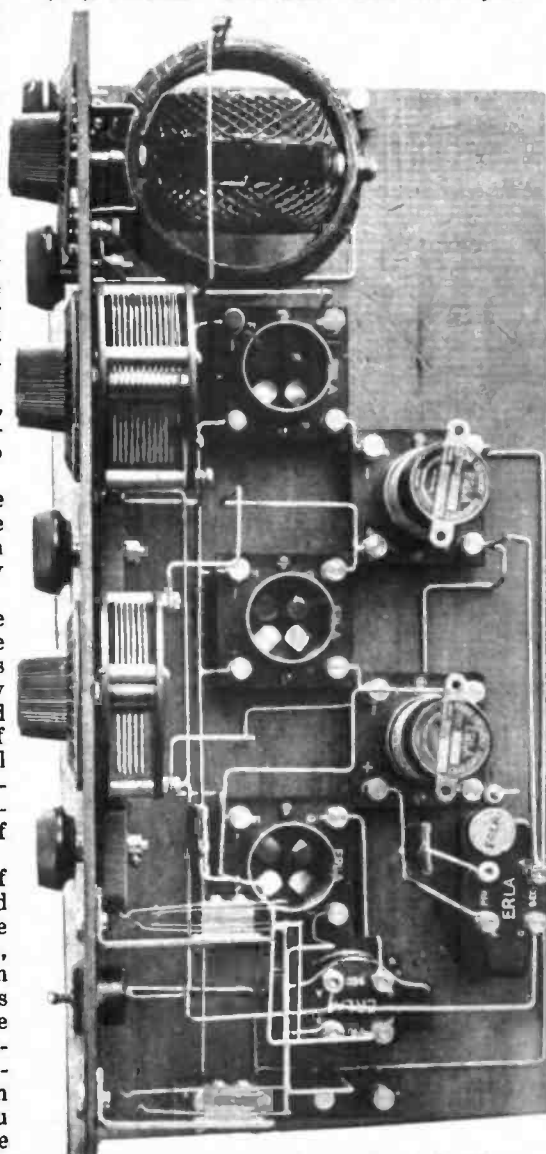

Looking straight down on the Erla three-tube reflex baseboard

A Two Stage Amplifier Unit

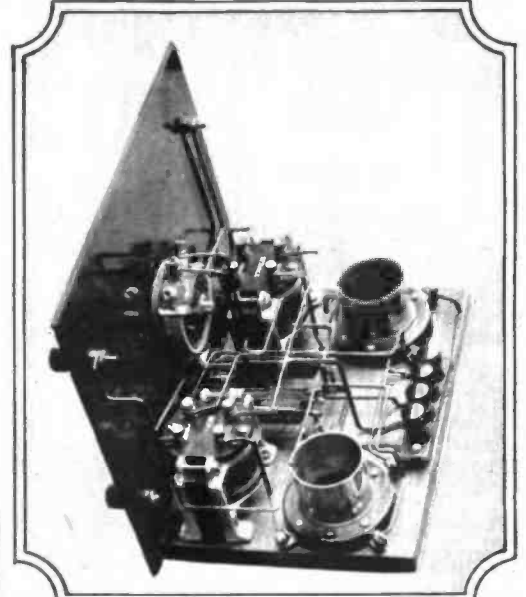
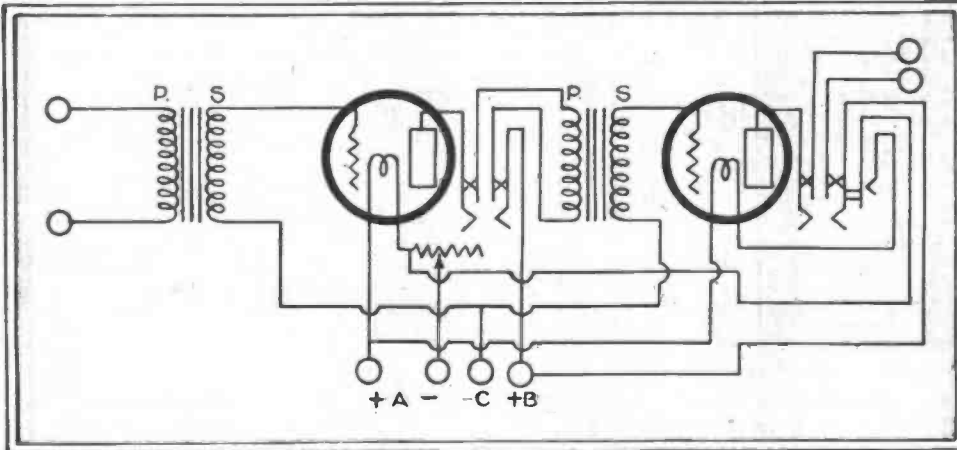

NO QUESTION comes oftener to this office than, "How can I add two steps of audio frequency amplification to my detector?"

I am giving here about the best outfit for two steps of amplification to be added to almost any detector circuit. I am giving it especially prepared for the A tubes, which function best as amplifiers when they have a C battery. A C battery, in case you do not know, is a little group of dry cells totaling from three to nine volts, the negative side of which is connected through the transformers to the grids of the tubes. The positive side of the C battery is connected to the positive side of the A, or filament lighting battery.

In this outfit it is unnecessary to have the negative side of the B connected, as that goes to the positive side of the B battery you are using on your detector. In other words, you now have the plus 22½ volt connection of your present B battery connected to your detector tube and you simply run another wire from that same plus 22½ volt-tap to the minus side of a new 45 volt B battery which must be used

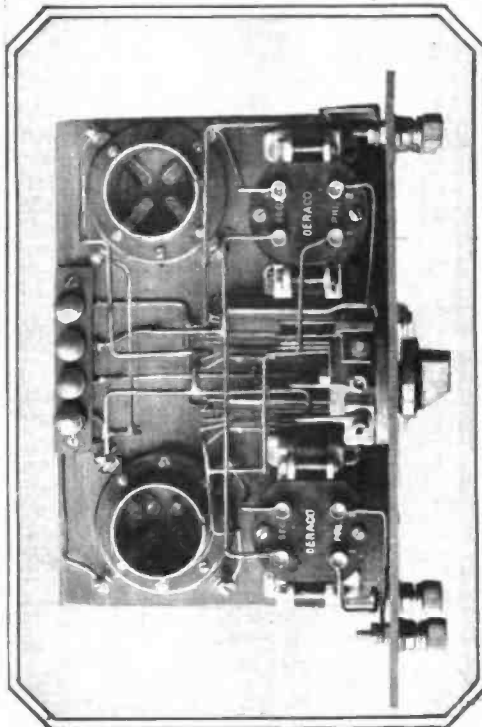

with this outfit. I am showing this unit with what is known as a "filament control jack." Both of the tubes are controlled by the same rheostat, but the first tube lights as soon as you turn the rheostat on. You can plug your phones into the first jack and listen on one step of audio frequency amplification and the second tube of this panel does not light.

When you plug your phones into the second jack, however, the second tube lights and you are listening in on the detector and two stages of amplification.

I am showing here the outfit just as we built it at 3XP, using the following parts:

Two Geraco audio frequency transformers, one Pacent rheostat and two Pacent jacks, two Paragon sockets and Eby binding posts throughout. Any other standard parts will do, but let me say that I feel that you ought always to use Eby binding posts for your battery binding posts, whether

(Continued on Page 46)

At the top is the regular electrical symbol diagram of this two-step outfit and just below it is the picture diagram. The other three illustrations show various views of the unit as built at Station 3XP

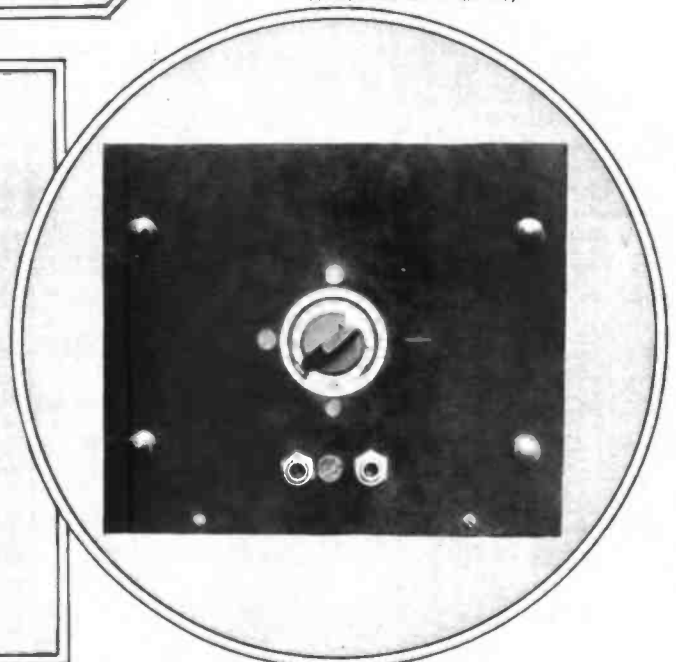
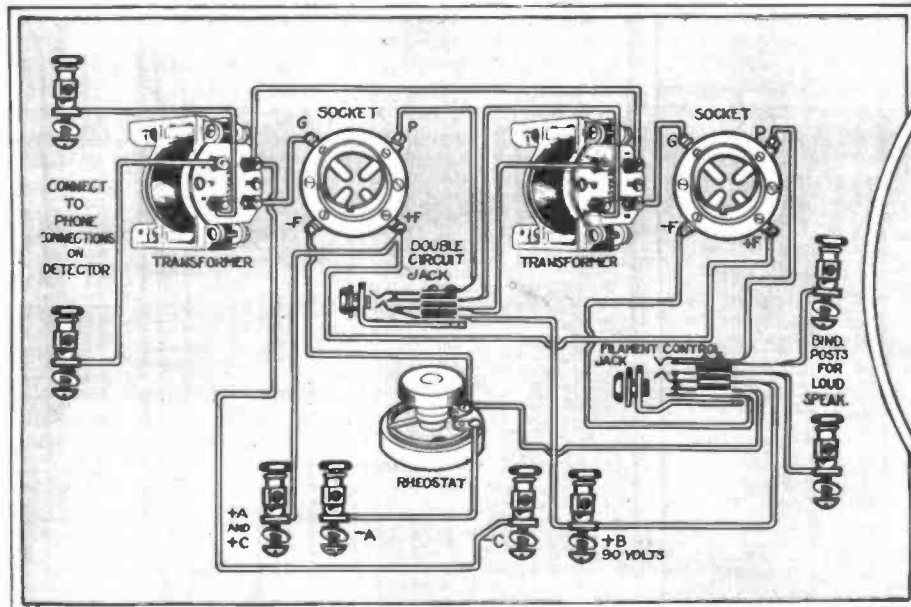



LESSON TWO

ALL OF the little children who attended the first meeting of our kindergarten last month heard a great many things about electricity that they may have forgotten by this time, but there are two things that I hope they have not forgotten because they are very important.

One of these is that electricity and magnetism are two different things—that electricity travels along some kind of conductor and that it is possible to put different materials in the path of electricity and stop its flow, or insulate it, but that magnetism travels through everything and it is impossible to stop its flow or insulate it.

The second thing which you must remember is that whenever you send a current of electricity through a conductor, it creates a whirl of magnetism through the ether about it and if this whirl of magnetism cuts through another wire or conductor, it will create another current of actual electricity in that second wire, even though the two wires are not connected to each other.

As I told you in the last lesson, this latter phenomenon of the creation of electricity in one wire by means of magnetism from a current of electricity in another wire is what we call "induction."

I hate to use such big words as "induction" to such a very young class as we have with us in this kindergarten, but you must be very patient in these few lessons because some of the words we shall learn are really quite important.

I want you to be particularly careful to get a good and clear mental picture of this process of induction, because radio is absolutely founded upon this phenomenon and could not exist without it.

Let us place here upon the teacher's desk a few little articles with which you are all very familiar and let us do some simple experiments with them.

Here, for instance, we have an ordinary battery. It doesn't matter whether it is a dry cell or a storage battery or an Edison primary cell—the only thing that you need to know is that it is some sort of a device for creating a current of electricity to flow in the wires which we have connected to it.

And here we have a little instrument which looks very much like the face of a clock with only one hand to it. This hand is always in the center of the scale, or zero mark, and the zero mark is in the position of the twelve o'clock mark on a clock face. You will notice the dial reads from zero on up to the higher figures to the right and reads exactly the same way to the left. In other words, the little hand or needle can swing in either direction and the dial will show you how many degrees it has swung.

Now let us try a very simple experiment. Let us take one wire from our battery and connect it to one of the binding posts on this little instrument and then let us take the other wire from the battery and with its free hand touch the other binding post on this instrument.

Immediately the needle will swing very decidedly to one side. It may go up to 10 or 20 or 100 of the divisions on the right or the left. It doesn't matter whether it goes to right or left, you will find when it goes over there it stays there steadily and does not fluctuate while the wires connect.

This little device is a measuring instrument by which we can tell whether or not there is a current of electricity passing through it and how strong the current is. When the needle goes over to one side and stays there it proves two things.

First, it proves that there is an actual current of electricity flowing through the wire and, second, the fact that the needle remains stationary in the position to which it flies shows that the current that is coming from the battery goes steadily and uninterruptedly in the same direction all the time.

This current then is what we call a "direct" current—that is, it goes in one direction only and keeps going steadily in that direction.

Now let us take the free end of one of our wires from the battery and touch it and take it away from the connection of the instrument very rapidly. Every time we touch the connection, the needle will fly up to its place and every time we take the wire away it will fly back again to zero. So it will keep flying up and back and up and back every time we touch and take away the wire.

The needle will always, of course, go in the same direction when we do this, which

shows that the current of electricity is flowing always in the same direction, or it is still a "direct" current, but the fact that the needle flies back again every time we take the wire away shows that when we take the wire away the current stops flowing. This gives us what we know in radio as an "interrupted direct" current.

We use both of these kinds of current in radio. We use the steady direct current from a battery to light the filaments of our bulbs. We use the interrupted direct current from our B batteries to our plate, passing through our telephones or loud speakers, and these interruptions in the current from the B battery are the forces that cause the diaphragm of the telephones or loud speakers to vibrate and create the same sound that caused the original radio current in the transmitting station when the speaker started to talk or the singer started to sing.

But these two kinds of current are not the only ones that we have.

In almost all of our house lighting circuits there is a flowing circuit of electricity which lights the bulbs in our house chandeliers.

Let us now place this little measuring instrument in the circuit to one of the lights in these chandeliers and see what happens.

Immediately the needle of the instrument becomes very much excited. First it flies away over to the right and then it comes back and flies away over to the left and back to the right and the left so fast that the eye can hardly follow it. As a matter of fact, it will do this so rapidly as to make one complete trip all the way over to the right and all the way over to the left and back to zero sixty times in each second. This, then, is what we call a "sixty cycle" current, and that is the usual current for lighting our houses.

By a "cycle," we mean a complete trip all the way over to one side and all the way over to the other side and back to zero by the needle.

This kind of current is what we call "alternating"—that is, it goes first in one direction and then reverses itself and flows in the opposite direction and these changes in its direction are shown by the needle of our measuring instrument going first to the right and then to the left.

We say that the current is first "positive" and then "negative." We say that the current alternates from positive to negative and that is why we call it an alternating current. And when we say it is a sixty-cycle current we mean that it is first





positive and then negative sixty times per second or, as there are two impulses—one positive and one negative—for each cycle, we say that there are 120 alternations. This means that there are two alternations to each cycle.

In speaking of a current of this kind which alternates sixty times per second we would say it has a "frequency" of sixty. Now perhaps you will be able to understand the latest government announcements about radio in which the wave lengths are translated into what the experts call "kilocycles." This is perfectly easy to understand when you know that the word "kilo" simply means "one thousand," and so a frequency of one kilocycle means that there are one thousand cycles or two thousand alternations from positive to negative in each second of time.

Perhaps this seems to you like an incredible number of reversals for a current to make in such a very short time as one second. But, as I told you when the class met for the first lesson last month, when we talked about radio we are dealing with speeds and with phenomena which are almost beyond human comprehension. As a matter of fact, in radio, a frequency of one thousand cycles or one kilocycle per second is extremely slow.

When an amateur sending station is transmitting on a wave length of 200 meters, the current is alternating so fast that it makes one million and a half complete cycles, or three million alternations from positive to negative, every single second in which his key is pressed down or the radio transmission is going on.

Three million alternations a second seems to be about the limit of possibility, but it is not. We have now developed amateur transmission apparatus—and in fact amateurs are now experimenting quite widely—with a wave length of 100 meters, and 100 meters in wave length means a frequency of three million cycles or *six million complete reversals from positive to negative every single second!*

You will see now why I told you in the first lesson that you must be prepared for staggering figures when you try to get a mental picture of the marvels that go on in your radio set.

There is one general principle you will notice in this, and that is that the lower the wave length the higher the frequency of alternation per second. Thus, at 100 meters the frequency is three million cycles, whereas at 300 meters the frequency is only one million cycles. Whenever you know the wave length you can easily figure

out the number of cycles per second by dividing the wave length into the figure 300,000,000.

And, if you see a report which only gives the number of cycles you can find the wave length by dividing three hundred million by the number of cycles per second.

But let us get back to the picture of induction which we tried to get in our minds last month. Without going all over the theory again, let us go back to the teacher's desk and perform some more simple experiments with the instruments which we have.

Now we are going to connect the apparatus in a little different way. We are going to take the wires from our battery and hook them to an ordinary switch by which we can either cause the current to flow or open the circuit and stop it. We are not going to put the measuring instruments in this circuit at all. This circuit will be absolutely independent and will consist of nothing but the battery, the wires and the switch. We will call it the primary circuit because it is the one in which the electrical impulses originate.

Now we are going to take a totally separate piece of wire and lay it alongside of and right up against one of the wires from the battery, but we are going to connect the two ends of the second wires to the two connections on our measuring instrument.

Now let us close the switch and allow the current of electricity to flow from the battery through its own circuit of wire. What do we see?

As soon as we close the switch, the needle of our indicator immediately flies over to one side. We know that the needle will not move unless there is a current of electricity flowing through the instrument and yet the wire that is attached to this instrument has no connection whatever with the wires attached to the battery. The two wires are simply lying along side of each other; both wires are insulated and so the metal of one cannot touch the metal of the other, and we know that the electricity will not go through the insulation.

Yet there is undoubtedly a current of electricity in this other circuit or else the needle would not have flown over to one side.

There is only one conclusion that we can draw from what we learned in the first lesson. That is that the minute we closed the switch and started a current of electricity through the first circuit, it sent out a whirl of magnetism and the moment this whirl of magnetism cut through the second wire, it created or "induced" a current of electricity in that second wire and that current made the needle go over to one side.

There is another remarkable fact that we will notice when we perform this experiment, and that is that when we close the key of the first circuit the needle flies over to one side, but immediately flies back to zero even though the key remains closed and the direct current continues to flow in the first circuit. In other words, we have simply created a momentary impulse of electricity in the second circuit.

It will be natural to suppose that when we open the switch in the first circuit nothing at all will happen in the second because we are not creating a flow of electricity so far as we know. Let us try it, though, and see.

We open the switch and immediately a remarkable thing happens; the needle of the measuring instrument in the second circuit immediately flies over in the opposite direction to the one it took before and immediately flies back again to zero.

This shows that, when we made the circuit, we created a momentary flow of electricity in one direction in the second circuit and when we broke the first circuit we created a momentary flow in the opposite direction in the second circuit.

We can draw from this the conclusion that magnetism will create electricity in the second circuit only when that magnetism is in action.

In case we want to prove that the magnetism remains around the first wire all the time the key is closed, although it shows no indication on our measuring instrument, we can prove it by another very simple experiment.

Let us take the ordinary little compass that Boy Scouts and hunters carry in their pockets. We know that this compass needle always points to the north. We

(Continued on Page 42)



The Little Wonder of Radio The "N" Tube

The first time I ever saw Ted Volten, I noticed that he wore as a watch charm a tiny radio tube which was only about an inch high and about the size of your little finger. I asked him what it was and he told me that it was the most remarkable tube that he had ever run across in radio. For some time we were not able to discover this tube, and when finally we did find it, it was being put on the market. I asked Ted to make a simple hook-up so that radio fans could get an introduction to the new tube in the easiest manner possible. And so Ted has written this article. He and I have worked with this "N" tube in various hook-ups, and I am willing to back up anything that he says about it.
—H. M. N.

By THEODORE F. VOLLTEN

IS THIS the tube you have been looking for? I know it is the one I have been looking for for the last three years.

About that time, when I was employed in the Government service in the Navy Yard at Washington, there came out a tube made by the Western Electric Company which they called the "N" tube. After the Government had made a great number of tests of this tube and declared it to be one of the best detectors and radio frequency amplifiers that they had ever tried, I naturally supposed that it would be on the market, so with this in mind I made for myself six sockets, but to my surprise and dismay I found out that, due to the agreement made between the General Electric Company and the Western Electric Company, it is impossible to manufacture these tubes in America except to be used in their own apparatus for the telephone companies which use them as repeaters or amplification boosters.

For three years after the tube was first shown in the Washington Navy Yard I have been looking everywhere to see if it were possible to get one. Until recently I was unable to locate any of them and I knew that they were using them in the telephone system, but they checked up so closely on them that it was impossible for any one to get hold of them.

One day in my travels around Philadelphia to the different radio stores I dropped into one and to my surprise they had quite a few of these so-called "Peanut Tubes" or "N" tubes. I inquired about this and wanted to know how they came to have them. It appears that they came from the Northern Electric Company, Ltd., of Canada, which appar-

ently is a branch of the Western Electric Company of the U. S. A. and is entitled to manufacture them in Canada. The store I visited had their purchasing agent up in Canada when he saw these tubes. He purchased quite a number of them and brought them into America, duty paid. The customs officials heard that these tubes were here and immediately inquired how they were purchased, but proof was shown them that the firm had purchased these tubes and had also paid the duty on them and that they were manufactured in Canada.

Several stores now have these tubes and they are on sale at \$7 apiece, and at that figure it is well worth the price for, as a radio frequency amplifier, this new "N" tube is impossible to touch with any other tube on the market.

It is considerably smaller than even the new UV199 tubes. A good way to illustrate this tube is to say that it is just about the size of your little finger. That hits it just about right. The outside diameter is about 9-16 of an inch and the length is about 1½ inches. It has the regular plate, grid and filament connections as they are in any other tubes, but, of course, with a smaller socket. It uses the filament which is the patent held by the Western Electric Company and the filament burns at a very dull glow, or at a cherry red and not an incandescent filament like others on the market.

This tube uses 11-10 volts for this coated filament and one-quarter of an ampere. That would mean that this tube is very adaptable for use with the dry cell.

The plate voltage for a detector is between 17 and 22; as an amplifier the plate voltage should never be over 45. Out at

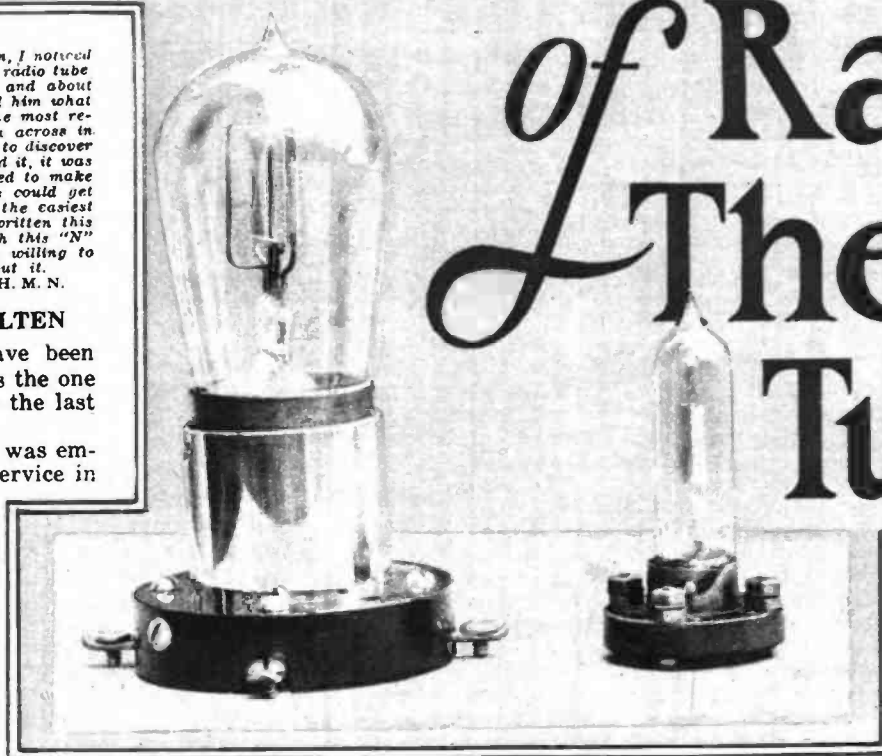

This shows the little "N" tube in comparison with the standard UV201A tube

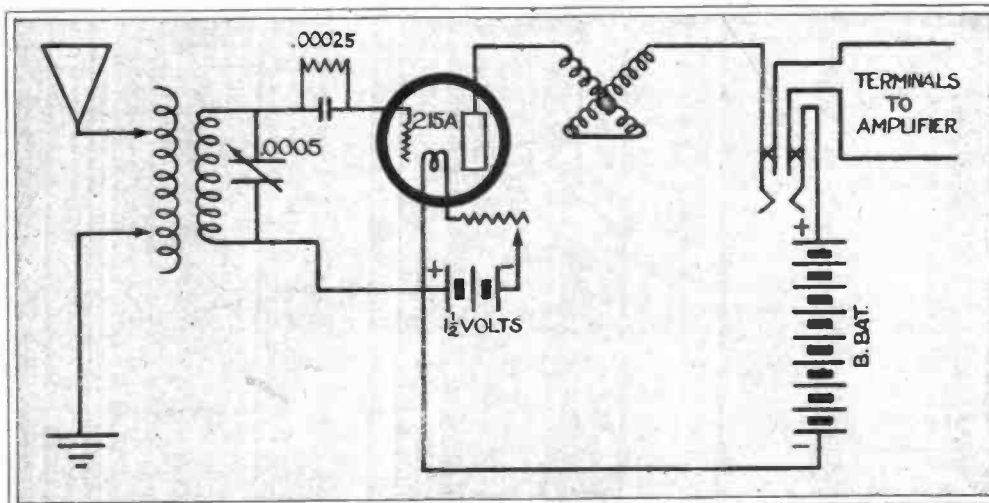

This simple diagram shows the hook-up for the "N" tube with the instruments mentioned in this article

Therefore it was legal to sell them in this country, but every tube has to be stamped "made in Canada."

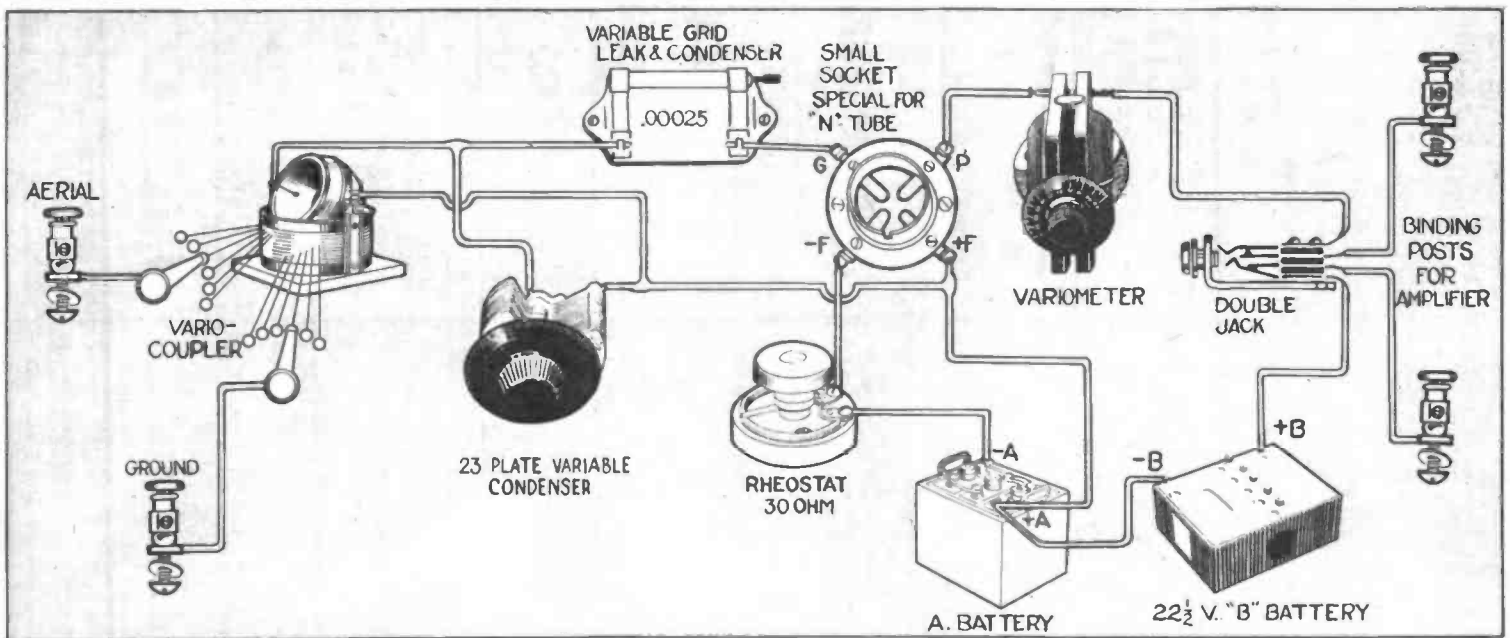

Above is the picture diagram of the hook-up of the "N" tube in the double circuit tuner

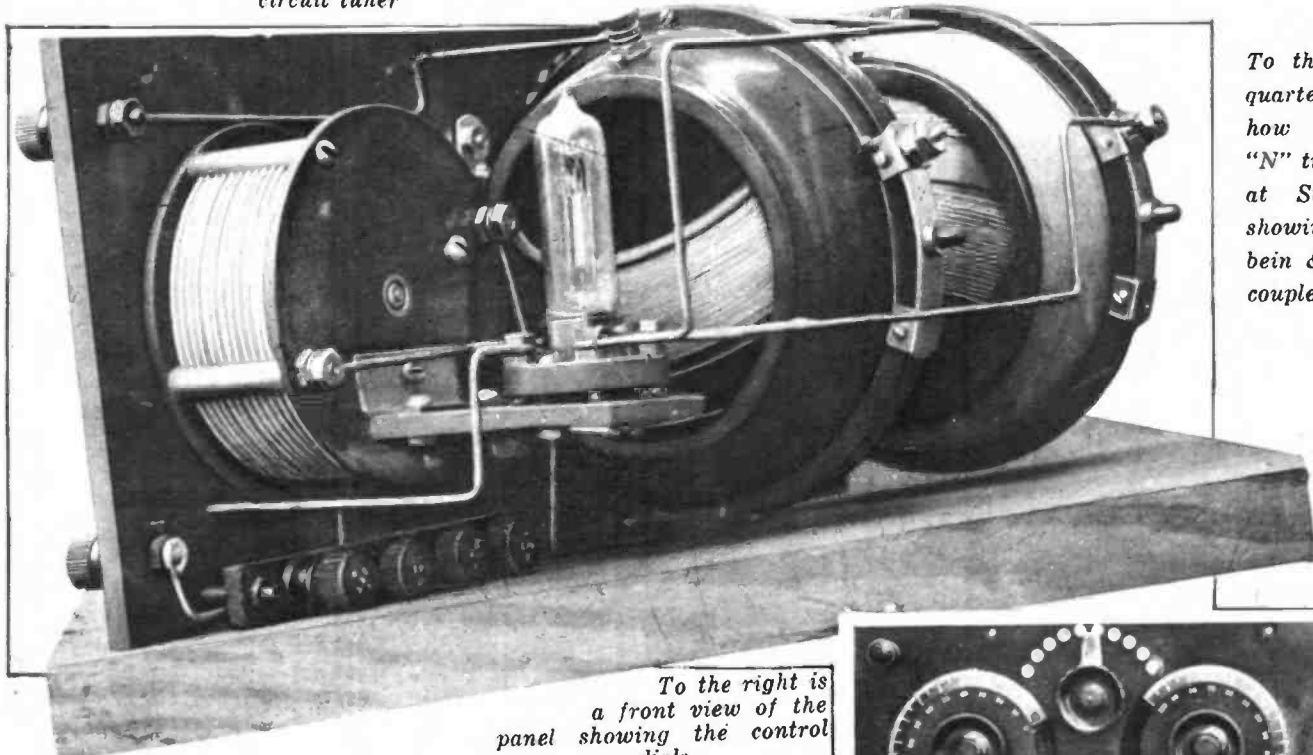

To the left is a three-quarter view showing how we mounted the "N" tube in our hook-up at Station 3XP and showing also the Langbein & Kaufman vario-coupler and variometer

To the right is a front view of the panel showing the control dials

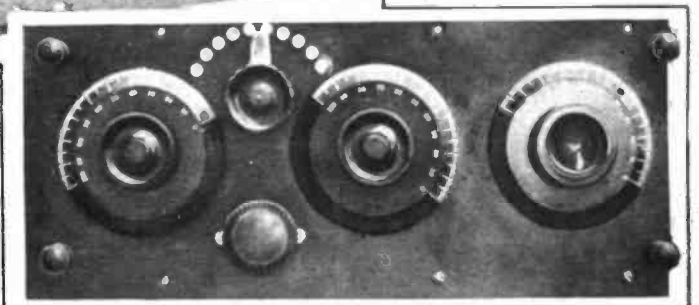

Station 3XP we have started to build a five-stage radio frequency amplifier. This is on the way now and we will show it in a coming issue. Meanwhile, to show you that this tube is such a wonderful detector, we made up a small circuit which is very compact and can be put in a desk drawer or a sewing machine drawer, or even in a vanity box or sewing basket. This circuit is the plain "two circuit" tuner using a vario-coupler and a variometer and a variable condenser with the new "N" tube as the detector.

The panel is 12 inches long by 5 inches high and it can be either of hard rubber or bakelite. The variable condenser is .0005 capacity.

There is an old saying that the nicer you make a radio set look the poorer it works. That, however, in this case, is not so. We are using here in this little circuit

a variocoupler and a variometer made by the Langbein & Kaufman Company of New Haven, Conn. I do not believe that I have seen anywhere such a nice piece of work as this variocoupler and variometer. It is beautiful. The windings are of a gold color wire and the composition which holds the windings in place is of molded bakelite. This apparatus works just as well as it looks. We have tried it in this little circuit and in other circuits and we find it ideal. The instruments are pretty and are easy to wire up and they add considerably to the good looks of the set.

The primary of the variocoupler has eighteen taps. Nine of these taps are single turns for the fine adjustment and the other nine are taps for the coarse adjustment. Here in this circuit I did not have room to use all of these taps, so I used only

ten of them. I used all of the taps of ten each and the beginning of the unit tap and the end of the unit tap, which makes ten taps in all.

I get very fine adjustment with this and I have no trouble in bringing in distant stations. The secondary of this variocoupler is connected across the variable condenser. The variometer has at the top two binding posts, which are the two regular external connections. One of these goes directly to the plate and the other goes to the telephone binding post.

The small "N" tube is shown with its socket mounted behind the variable con-

(Continued on Page 45)



Editorially Speaking and

By HENRY M. NEELY

IN VIRTUALLY every first class broadcasting station in this country today an attempt is being made to answer such questions as, "What does the public want? What shall we give them? How can we find out so that we may put broadcasting upon such a solid foundation that radio will endure and go on in its growth?"

What Does the Radio Public Want?

Perhaps you, when you listen

in, become rather tired of the announcer's repeated requests that you write to him, or rather to the station, and tell what you want. But he is not doing this as a matter of form. He is doing it in a sincere attempt to analyze the public and the public's taste. That is what his superior officers want to find out.

Very many hundreds of thousands of dollars are being spent today in the attempt to solve the riddle of the public demand in broadcasting. In virtually every case, the people who are doing this are founding their investigations upon the results of the letters that they receive, and very elaborate and expensive systems have been devised and put in operation to classify all of these letters and analyze them.

On the face of this you will be inclined to say that this is a very laudable movement and that it is bound to result some day in the solution of the problem of broadcasting.

But will it? Personally, I believe that all of these attempts, however well meant, are futile and utterly useless.

The public taste will never in this world be a fit subject for scientific analysis nor for an efficiency expert's diagnosis based upon facts and figures. Facts and figures have nothing whatever to do with public taste. By the time you have compiled your

facts and figures and analyzed them, the public taste has changed and you have got to begin your job all over again.

No broadcasting station will ever be made a success by means of analysis and investigation.

There is an old saying that every successful man thinks there are three things which he could run with tremendous success.

These three things are a hotel, a theatre and a newspaper.

The average successful business man cannot see that the running of any one of these requires anything at all outside of the ordinary ability that it requires to run a successful mercantile business. He feels certain that he could analyze the situation in any one of these three businesses and run the concern successfully from the result of this analysis.

Let me say that if this could be done there would be no failures in the theatrical business, the hotel business or the newspaper business. If the public taste could be analyzed from facts and figures, from

diagrams and graphs, from equations and mathematical formulae, theatrical playrights would be lending John D. Rockefeller money, hotel proprietors would be acquiring ownership in the United States Steel Corporation and *Radio in the Home* would be in a position to pay the national debt of Germany.

I have been a newspaper man for twenty-seven years, during a great part of which I have been very closely associated with the theatrical business. Consequently I am not at all unfamiliar with the conditions of these two businesses, though I confess I know nothing about keeping a hotel beyond the partial insight which we, in the old days, were able to get by walking in through the swinging doors,

I am going to speak now of the newspaper business and my remarks apply equally well to those other two businesses. Incidentally let me say that I am doing this because I am firmly convinced that the radio industry of today is fundamentally the same as the newspaper and the theatrical business, though it may differ somewhat from the hotel.

First and foremost in my complaint against the present system of investigation of the radio business is that radio broadcasting stations are trying to do something which newspapers and theatres long ago found to be impossible. Radio is trying to be all things to all men. That cannot be done.

NO NEWSPAPER editor attempts to turn out the kind of paper that will appeal to the lowest grade of intelligence as well as the highest. We have our "yellow" sheets that are designed especially for the uneducated masses and we have our fine, substantial, intelligently run newspapers that ignore the masses and appeal only to the educated and the cultured.

And the same holds good in the magazine field and with hotels.

Our theatres are divided in the same way. We have in every city a theatre which has a following won by many years of consistent-

still Editorially Speaking



ently putting on the highest grade of plays, and another which puts on the lower-grade plays; there is a theatre which is intended entirely for burlesque, another which is a vaudeville house, another theatre which usually fills its bills with musical comedy and the more frivolous side of stage production.

When the moving-picture industry first started it tried to do what radio is now trying to do. It tried to put out motion-picture productions that would appeal to everybody everywhere. At first the novelty of the motion picture carried it along and many millions of dollars were made. But soon the public began to divide itself into its inevitable classes and the motion picture today is on the decline simply because the producers will not realize that fact and will not divide themselves and their theatres in such a way as to specialize in the various classes of public taste.

Radio will decline in the same way unless the men behind the industry realize that this division of quality is absolutely essential to success. There are enough classes and enough people to make broadcasting stations of various kinds possible and profitable to the radio industry, but so long as broadcasting stations attempt to please everybody the result is bound to be chaos and a hodge-podge of stuff which will meet with unfavorable criticism in some of its aspects from everybody.

You cannot analyze

the public taste. You cannot balance up a column of figures and say, "Here; this is what the public wants."

If you could, you would have statisticians as the editors of your newspapers and public accountants as the managers of your theatres.

THE great editor who carries a newspaper to tremendous success does it because he has a God-given instinct that

Letters Are Not Good As an Index

makes him sense intuitively what his own particular public wants. He may be getting out a yellow sheet or may be editing a Boston Transcript, but whatever his sphere of efforts may be, his instinct is not a matter of reasoning, nor a matter of figures, nor a matter of analysis; take a proposition to him and place it before him and he will immediately give you an answer upon it because he himself has that feeling of undefinable touch with his public that requires no investigation and that will deliberately ignore the report of any so-

men who have this instinct and who can go enerringly along their path of progress, always taking with them the public to whom their station is designed to appeal.

This class of man has not yet been put in charge of broadcasting stations. He is an extremely expensive man. If he has this instinct, he can make ten times as much money in some other business as any broadcasting station has yet offered a director.

Such a man would laugh at your reports of analysis and would

brush aside in contempt all of your elaborate sheets of paper with tabulations of what the public wants.

In the first place let me say one thing about the public.

Everybody who has been in the newspaper business very long knows that the yellow sheet will receive fifty times as many letters from readers as will the fine and substantial newspaper designed to appeal to the more intelligent classes.

The cultured and intelligent classes do not write letters wholesale. It is very difficult to get them to send a letter to people whom they do not know and they have an instinctive feeling that it is not good form for them to write criticisms of another man who is attempting to carry on his own business.

The lighter and more frivolous and less educated people, however, are very free in their correspondence. Turn to any of the most popular newspapers—particularly those who specialize in women's pages of the "sob" variety—and read the sheaf of letters from readers published daily. Look over those letters and see how they are worded and study the type of mind which they represent.

Is that the type of mind you think is going to make the success of a great industry such as radio ought to be?

(Continued on Page 39)

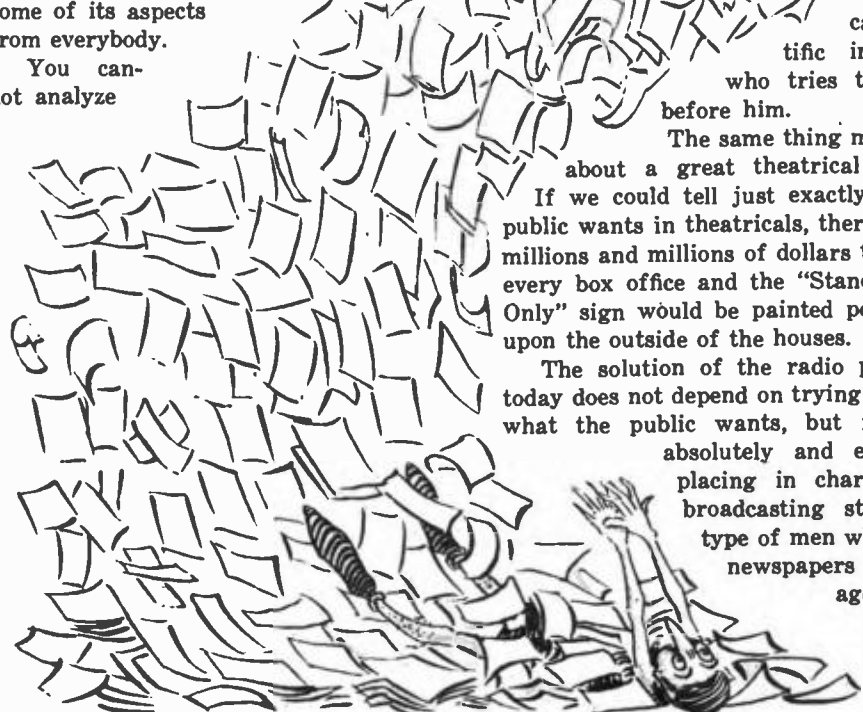

called scientific investigator who tries to place it before him.

The same thing may be said about a great theatrical producer.

If we could tell just exactly what the public wants in theatricals, there would be millions and millions of dollars taken in at every box office and the "Standing Room Only" sign would be painted permanently upon the outside of the houses.

The solution of the radio problem of today does not depend on trying to find out what the public wants, but it depends absolutely and entirely on placing in charge of our broadcasting stations the type of men who edit our newspapers and manage our theatres. The type of

The Woman's Club in Our Town Discovers Radio



"The woman in the small town can keep in touch with everything that is going on beyond the county limits."

By

SIDNEY LEAR

THE Woman's Club of Everytown is right at the height of its activity. One-act plays are being looked over for the midwinter entertainment, committees for this and that are being selected, new members are being taken in, and subjects for debate and discussion are being thought up—and all that kind of thing.

But the Woman's Club of Our Town has made a great discovery—a discovery that has made the winter prospect brighter for more than two-thirds of the members. And nobody tried to make it, either. It just happened itself.

In this way. The president of the club, although she is one of the most active and interested clubwomen in Our Town, has one of those husbands. You know the kind. He insists upon coming for his wife after

every meeting because he doesn't want her to come home alone and he doesn't trust to the kindness of friends with cars, but he crabs and crabs and crabs every year, every month, every week, every meeting night, about her belonging to the club at all. He is one of those men who think a woman ought to be glad to sit down comfortably in the living room she has been cleaning or helping clean all day long, after a hard day of doing nothing but stick around the house. He is so glad to get to his home himself at night that he can't see why "a woman has to be running around at night all the time"—but you know the kind of man that's meant? The typical stay-at-home husband.

After the usual protest, explanation and resigned grunt, the president left him to go to one of the meetings early in the season. He was contentedly reading his paper in the living room all evening and he grunted a lot more when he found that he had to go out at ten o'clock and bring his wife home. And he was inwardly grunting—but only his wife knew that—when he smiled cheerily twenty minutes later, and accepted a friend's invitation to ride home in the car with them and stop in for a minute or two, 'twasn't late.

And oh, how bored he

was when his host made the inevitable move toward the radio set, wearing upon his face the inevitably proud smile, as if he had invented the whole idea himself. But then it happened.

The host's smile became broader and more as if he were about to show off his newest baby or his trick dog.

"Roll back the rugs, Sally!" he called in the loud, staccato voice which the wearing of the earphones breeds, "Charlie Kerr's orchestra has just started that good waltz from the St. James. Come on, Mrs. President; I want the first dance."

He set down the headpiece, made the necessary connections and bowed impressively as the loud speaker suddenly began demonstrating its usefulness in emphatic, rhythmic tones. He swung into the "good, old-fashioned waltz" with his guest and there was nothing for her husband to do but follow suit with his hostess. They danced until twelve o'clock, and the president's husband had the time of his life.

"That was certainly an enjoyable surprise," he announced, as they rolled homeward in their friend's car. "Little did I think when I started out tonight to get my wife that I would have a dance like that before I got back. I'm in favor of this woman's club movement!"

He laughed genially, little suspecting that the germ of a great idea was being brought to life in the fertile brain of the clever president. Little did he know about the conversation of certain ladies over a bridge table the next day, or the proposition put before the club very informally and frankly by the president at the very next meeting.

"I'm sure there are lots of you who

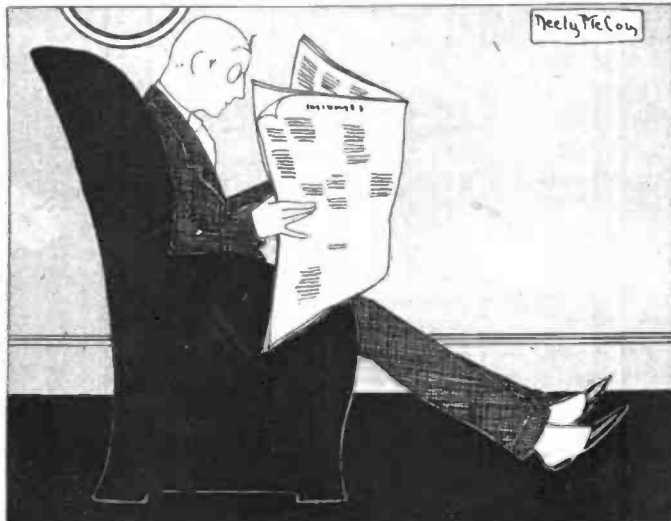

have this same difficulty," she concluded her little speech, "and I believe this would help us all out of it. And at the same time we can get a lot of fun out of it ourselves. What do you think?"

She was applauded vociferously and her plan was accepted without question.

And now the members of the club are planning an entertainment that will make Our Town sit up and take notice, so that they can raise money enough to install a radio set in their clubhouse. When they get it, equipped with loud speaker and plenty of power, they will have a bait, a pacifier, an entertainment and a diversion for the husbands and "friends" who are now either bored to death coming for them or skeptical of the joys of a woman's club.

A little dance party after they get there will do much to change their minds and gain their loyal support. And then, knowing the way to a man's heart, the club members plan to have one real party with eats and evening clothes and everything, once a month. Some ambitious souls are even talking about getting up a regular dancing class to meet at the club rooms every other week on nights when there are no regular club meetings.

This prospect, incidentally, has roused the interest of certain women in Our Town who have been somewhat bored at the idea of the club when they have been asked to join. A whole roomful of women talking their heads off about various uninteresting, dry things, they said, didn't somehow appeal to them. But a dance after the meeting, a party every month, sounds more real to them, and two have already capitulated. Probably after the radio set is in and the first party has been enjoyed and talked about the others will follow suit. Then they'll find out that the club has other nice things about it, too.

Of course, all the talk about this has stirred up greater interest than ever among the women who have radio sets in their own homes. Some of them have been busy with housecleaning and other things lately and have got out of the radio habit. Now they are turning back to it again, snatching a moment of listening whenever they have a chance. And they are finding that, no matter how long you have had your radio set and your radio interest, there is always the possibility of getting pleasure, education, entertainment and that old thrill of awe and wonder at the marvel of it.

And help, too—lots of help. One woman read a perfectly splendid review of one of the latest books recently at a meeting, and was congratulated warmly for it.

"Well, I'll have to be honest and give the credit where it's due," she admitted afterward, "I heard a review of that book on the radio the other day. Of course, I didn't use that review or even the idea suggested by it, but the woman who was talking gave me an entirely different viewpoint on it. I hadn't looked at it from that angle at all before that, but as I thought it over afterward I realized that you got a lot more out of it if you did look at it that way. It was just by chance that I heard it; I didn't know she was going to give a book review at all, but it was really very helpful to me."

Sixteen or eighteen women made mental notes of that information and watched the programs very closely after that. A book review or the intelligent discussion of a book is not the easiest thing in the world for an inexperienced person who has only her own opinion and lack of real knowledge to go on. Even if she is experienced, another point of view is always a help. It is helpful in current events as well as book reviews, too, and it is very often remarked now at the club, "As Mr. So and So said the other night over the radio—" "I heard some one say that very thing just last night over the radio." The current events talks are exceedingly popular, and for women who are getting ready for discussions or debates, or are striving to be right up to date on every subject, these short lectures are the greatest kind of boon.

Indeed, when you read over a radio program in the paper, you find over and over again, numbers that just seem to be made for clubwomen. In addition to book re-

views and current events talks, one day's program included: "The Home Beautiful," from WJY; "Educational Lecture," WOC; "Matinee Musicale," KHJ; "White House Announcements" and "Fashion News," from WRC, and a dramatic review of Leo Ditrichstein's new play from WDAR. The varied interests and ideas that are embodied in just these topics picked out at random from one day's list of events would furnish discussion and entertainment material for a club for a month.

Later on in the season, when worthwhile organizations begin to have banquets, with splendid and well-known speakers, many of them will be broadcast. Last year there were some delightfully entertaining affairs of this kind, to which, often, only men were invited. It is sometimes possible for women to go and look down upon these banquets from a balcony which overlooks the room, but not always, and even if it is, this is not entirely satisfactory. The speakers may be difficult to hear from above, and then the constant murmur which is inevitable at such a large dinner is likely to sound more noisy at that height than it does on the ground floor.

This does not "take" on the radio, however, the voices of the speakers coming over distinctly and with no interruption save the applause and occasional side remarks by the toast-master or some one else



sitting near the microphone. An interesting evening could be spent in the club rooms listening to the speeches and songs from one of these banquets—and probably will be by the Woman's Club of Our Town as soon as they get their big set installed.

The world in general has been missing and is now gaining a great deal in this one particular feature. No doubt as time goes on there will be even more of the large annual banquets broadcast, as the public shows more and more interest in getting something that it has never been able to get before except in fragmentary form in newspaper accounts the next day.

It has missed the spontaneous, simultaneous laughter that bursts out so surprisingly at the finish of a good story, the tenseness which can somehow be felt even

carelessly tossed napkins are bits of atmosphere that can be cheerfully dispensed with anyhow.

There won't be the awful drain upon the treasury of at least the Woman's Club in Our Town this winter to pay for the public speaker or prominent personage who is usually invited to come speak to the members and their friends once a year. This is always a gala occasion for the club, with gayety and merriment and importance on the surface and underneath a heavy dread that there won't be enough money to pay the entertainer's price without taking up a special collection outside of the regular dues. But not this year. Not in Our Woman's Club. Friends and relatives will be invited more often, to hear speakers and singers and musicians—*on the radio!*

meeting they have attended for several years, and they confess that they are usually bored stiff until time for the eats.

But this business of having a radio set, with the possibility of jazz music bursting in upon them at any minute, is something very else again! And dances every month that they can come to? Yes, indeed, they belong to the club, and just can't wait to start activities for the winter. They have already adopted a resolution to give their midwinter play at the broadcasting station nearest to Our Town, just before they give it at home. Or maybe just sing some of the songs from it so that people will be interested enough to come.

In Our Town especially, radio will make the club life ten times more interesting than it has ever been before, because Our



Radio in the Home of C. H. Griffith, 1422 Blavis Street, Philadelphia, Pennsylvania.

Photo by Henry S. Tarr—Courtesy of Gimbel Brothers, Philadelphia.

through the air as a speaker works up to a climax. The newspaper stories give the words, describe the appearance of the men and women who have talked, but they cannot reproduce the atmosphere of genial humor, amiable wisdom, intense interest and suspense which prevails as prominent statesmen, judges, humorists, clergymen, writers and our own inimitable E. J. Cattell are introduced and swing into their strides.

When you listen in, you get all that first hand, and your imagination can supply the tables of men, some smoking, some not, some turned half away from the table as they listen, others leaning easily upon the edge, or shifting about to get a better view of the speaker. The smoke-filled air, the forgotten coffee cups, the ash trays and

And the only cost will be the upkeep, and perhaps the refreshments, if there are any.

And speaking of refreshments, the junior branch of the Woman's Club is all excited and thrilled about the radio. In former years they didn't dare dream of having anything, scarcely a business meeting, without providing sandwiches or cakes and something seasonable to drink as a bait for certain members, a good percentage of them, who are not going to make good politicians when they reach voting age. These girls just simply don't care for club life and woman's interests. In fact, the very opposite of woman interests them far more than anything you could mention or even think of at the moment. They have been almost literally dragged to every

Town is not a city, and it is off the beaten track for lecturers and plays and musicians. It has always been necessary to go to the nearest city for those things, and the club has depended upon occasional trips en masse to hear something or see something, or upon the ingenuity of its own members for entertainment and variation of the monotony.

New ideas will just pour in this year with the radio set installed, and the myriad kinds of entertainment that it affords at hand for anybody who takes the slight trouble of making the connections. The woman in the small town can keep in touch with everything that is going on beyond the county limits now, right from the assembly room of her own Woman's Club.

A New Idea in Crystal Sets

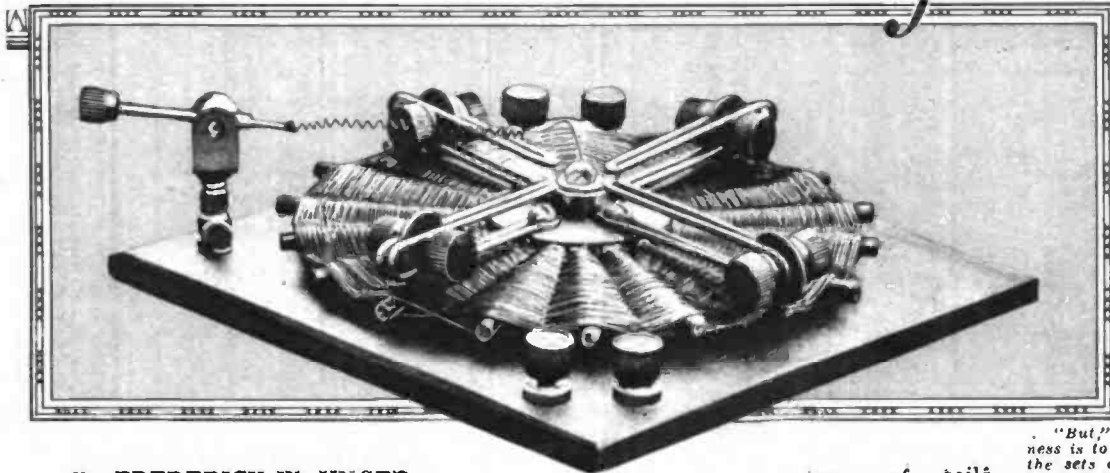

By FREDERICK W. UNGER

DESPITE the flood of poor crystals and even worse cat-whiskers, which flooded the market last season, crystal fans throughout the land, with the persistency of genius, patiently and tediously achieved more or less satisfactory results. Their numbers multiplied and remultiplied to countless thousands.

This fact alone indicates the tremendous grip radio reception has taken on a greater public than is generally realized.

I emphasize "poor" crystals and even worse, cat-whiskers.

Bought or home-made receiving sets—often of highest excellence in design and workmanship—suffered under the first-mentioned handicap.

Tirelessly hunting for a sensitive spot with a whisker—approximating the use of a crow bar to set the hairspring of a watch—was the usual practice and yet—the patient amateur got results.

A few obtained good crystals and proper cat-whiskers, and results followed which were surprising. Local reception of amazing loudness and occasional long-distance reception forced its attention upon incredulous experts and a more skeptical public.

Like the average novice, I bought a dozen, more or less, different crystals until the discovery of an unusual crystal material led me into their manufacture and sale. Then followed the discovery of the abominable cat-whisker situation and a commercial effort to remedy it.

Later a long siege of experimental work resulted in the production of a receiving set, as much in advance of other designs as the new crystal was in advance of the almost useless materials which preceded it.

Radio in the Home made a quick appraisal of its all-around superiority and after careful tests has adopted it.

In appearance its chief novelty is an adaptation of the spider web

form of coils. The winding is unusually intricate and can only be done satisfactorily by machine. It is equipped with four sliders, also of new design, enabling extremely sensitive tuning. These are in two pairs, distinguished by the colors red and black. In operating, the black sliders are used as though tuning a primary circuit and the red pair as though tuning a secondary or induction circuit. This is as technical as I intend to be, but will convey illuminating information to the initiated.

Two red binding posts receive the aerial and ground wires. Use either post for either wire.

For simple broadcast reception from local stations as short an aerial as twenty-five feet will suffice—but the longer the aerial the louder your reception will be.

A wire bedspring may be used as an aerial, but better results follow if the bedspring is connected to the ground wire and the aerial is made to take two or more turns around the top of the room, keeping each turn four to six inches apart.

To tune in, face the crystal set with the two red sliders at your right. Then move the two sliders nearest the cat-whisker post in toward the center (one black and one red). Draw the other red slider to the outermost wire of the coil, and then, with the remaining black slider at your left, move out slowly from the center until you pick up the station which may be broadcasting. Under these conditions, the shorter wave stations will be picked up first. The longer your aerial the nearer to

I first met Frederick W. Unger some twenty or twenty-five years ago when both of us were newspaper men. I found that in the mean time he had become intensely interested in crystals and had discovered mines in the west in which various crystals have been produced.

As we discussed crystals, I asked him what kind of a set he was using. He explained that it was a freak that he had devised himself.

This coil is a spiderweb coil and it is really two circuits wound on at the same time in a way that would be very difficult to explain. He made me up a set and I have tested it pretty thoroughly and do not hesitate to say that it is the sharpest tuning crystal set that I have ever used. I asked Mr. Unger to write an article telling about it and, if there seems to be enough interest among crystal fans in it, I think I could arrange with Mr. Unger to put it on the market within reach of everybody.

"But" Mr. Unger said, "don't forget that my business is to sell crystals and not coils or sets. I will sell the sets if they want them, but I'm in the game for crystals." —H. M. N.

the center you will pick them up with this slider.

As soon as you get some reception re-adjust your cat-whisker. The crystal I use is the Multi-Point High Power Crystal and practically has no dead spots. But the cat-whisker may press too hard or too lightly. Very little practice will enable you to get the high power out of this crystal, and at any rate you will not have to hunt for a spot to discover if broadcasting is going on.

You may then move the left-hand black slider back and front a few wires at a time until you get the loudest reception. After this, by moving the red slider nearest you a little, you may improve reception still more.

The above system of operating may be called tuning from the center. By placing the two first mentioned sliders on the outside rim of the coil instead of at the center, and likewise reversing the position of the other two sliders, you can tune from the outer edge.

This results in much sharper tuning and is more difficult. It will often result in greater volume of sound.

A word here as to the operation of the sliders. Occasionally slide each one back and forth their entire range to brighten up the bared parts of the coils. Otherwise operate the slider by pressing very lightly with the first and second fingers on the knobs, and roll in the slider back and forward. Often a movement from only one

wire to the next will give you surprising results, and the delicacy of this type of slider or roller will be quickly realized.

A few evenings of reception will take you out of the beginners' class. You will cease to be a novice. You will become ambitious to get long distance.

You can do it. Last season with a good crystal I occasionally picked up

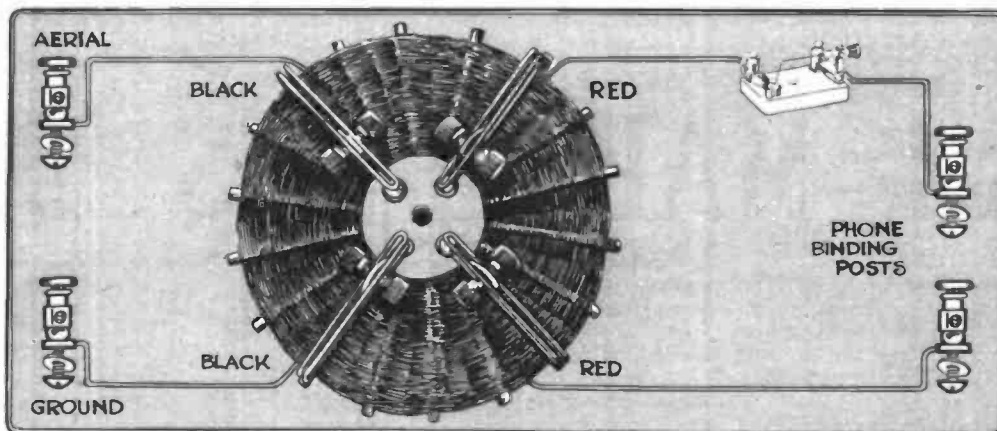

This is the Unger crystal hookup with his double-wound spiderweb coil

(Continued on Page 40)

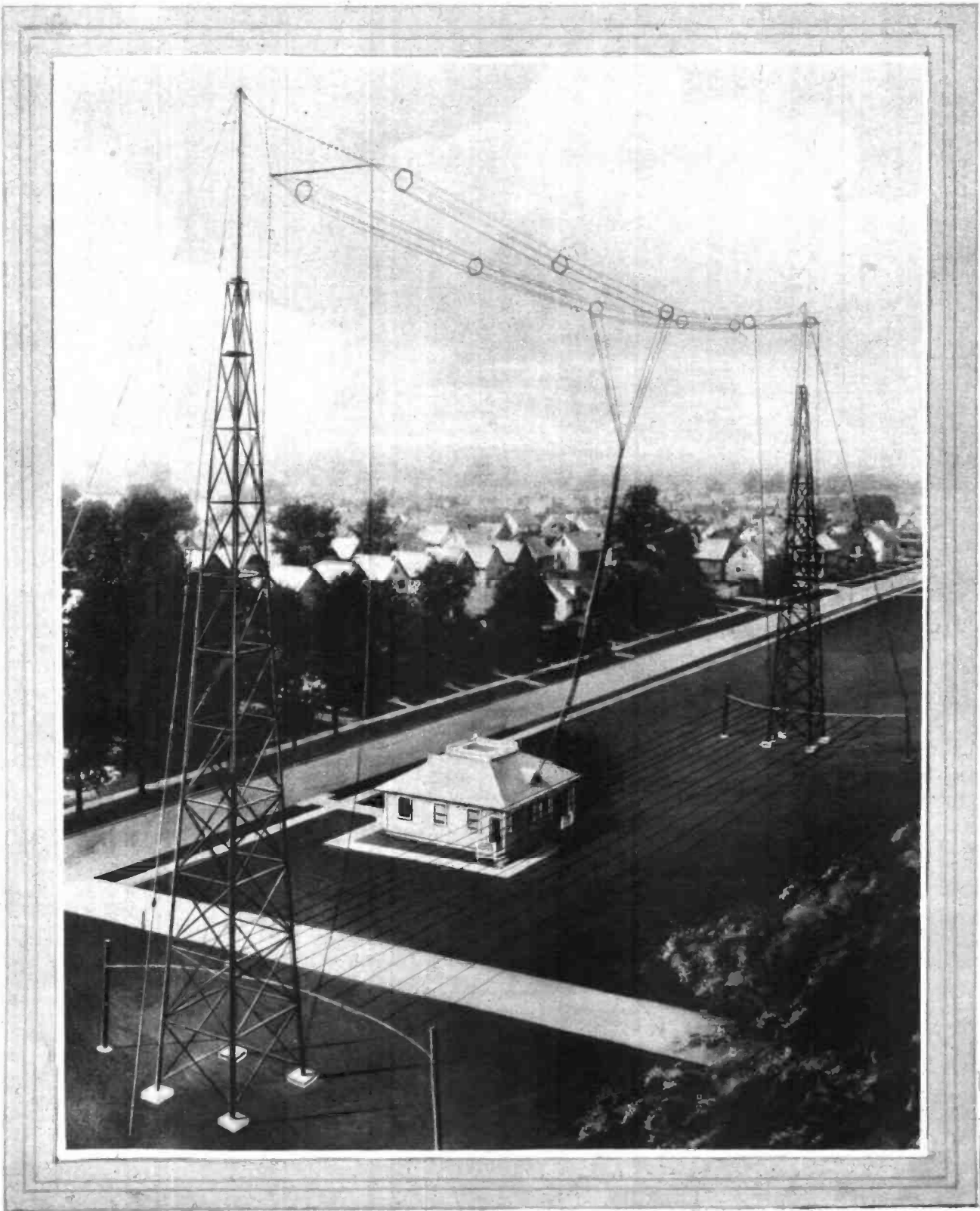

WTAM MAKES ITS DEBUT

A NEW and powerful broadcasting station recently made its initial bow to radio fans when WTAM, broadcasting station of the Willard Storage Battery Company of Cleveland put its first concert on the air Wednesday evening, September 26th.

On a wave length of 390 meters, this company, one of the largest and best known manufacturers of automobile and

radio batteries in the country, is broadcasting its programs from one of the most powerful stations yet built. WTAM has installed a 1000 watt transmitter, making it one of a very few with such high wattage.

The new station has been erected on a large lot adjoining the immense Willard plant. A substantial building to house the station provides separate rooms for the transmitting equipment, storage batteries,

reception parlor and studio, with commodious dressing rooms for the artists who will entertain the invisible audiences.

The outstanding and unique feature of the Willard station is that it not only has 1000 watts for transmitting, but that storage batteries, which have for some time been recognized as the ideal source of power for clear and steady transmission,

(Continued on Page 25)



Above is the studio of WTAM, and below is A. R. Herske, the announcer of



the new broadcasting station of the Willard Storage Battery Company

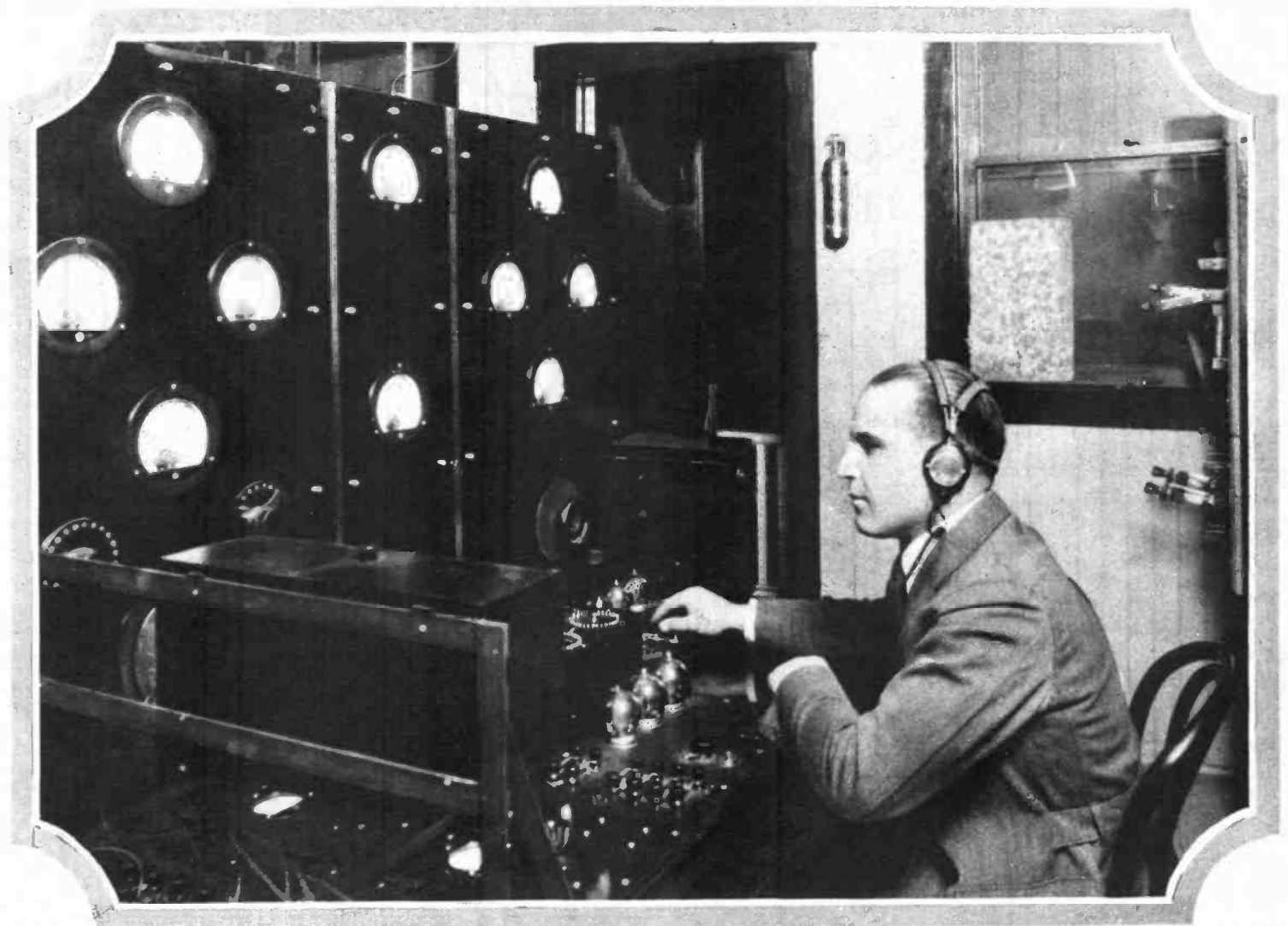

S. E. Leonard, operator of WTAM. Mr. Leonard designed and personally supervised the building and installing of this new station.

(Continued From Page 26)

are being used exclusively. Huge racks of storage cells provide the 2500 volts required by the 1000 watt transmitter.

The station has been so planned and built that no moving machinery is in or near the station. Even the machinery for control of ventilation and heating is remotely situated from the building.

An unusual form of aerial is employed, specially designed to eliminate static interference. The antenna consists of twelve wires in a double cage of six wires each.

This aerial has a span of 250 feet, with a weight of approximately 300 pounds. It is suspended at a height of about 138 feet between the two 140-foot towers. The towers are constructed of 4-inch angle iron to a height of 112 feet, the remaining distance being covered by 38-foot masts of wood. Stranded steel guys, with numerous strain insulators, are set into concrete piers for back bracing, and the legs of the towers are deeply seated in more massive piers of

concrete well founded in the solid earth.

A counterpoise, 60 feet wide and 250 feet long, is supported by 12-inch I beams 12 feet tall immediately beneath the spread of the aerial. This counterpoise is composed of twelve 250-foot lengths of antenna wire spaced five feet apart.

The station is ideally located for per-

fect transmission. Eight miles from the business center of Cleveland and one-half mile from Lake Erie, there is no disturbing element to mar its transmission. It is more than a quarter of a mile from the nearest electric car line, minimizing a factor which is often troublesome to broadcasting stations and to their audiences.

Cleveland's best entertainers are listed for this station. The Willard Company is determined to have nothing if not the best. Programs are broadcast on Wednesday and Saturday evenings of each week starting at 8 P. M. and 9 P. M. respectively.

The Willard Company set out with the idea of building one of the world's best broadcasting stations. Neither time nor expense has been spared in securing and setting up the most perfect equipment that has yet been conceived. In spite of its 1000 watts and its storage battery power it will still have several worthy competitors for first place, but it has already entered into the first rank of broadcasting stations.

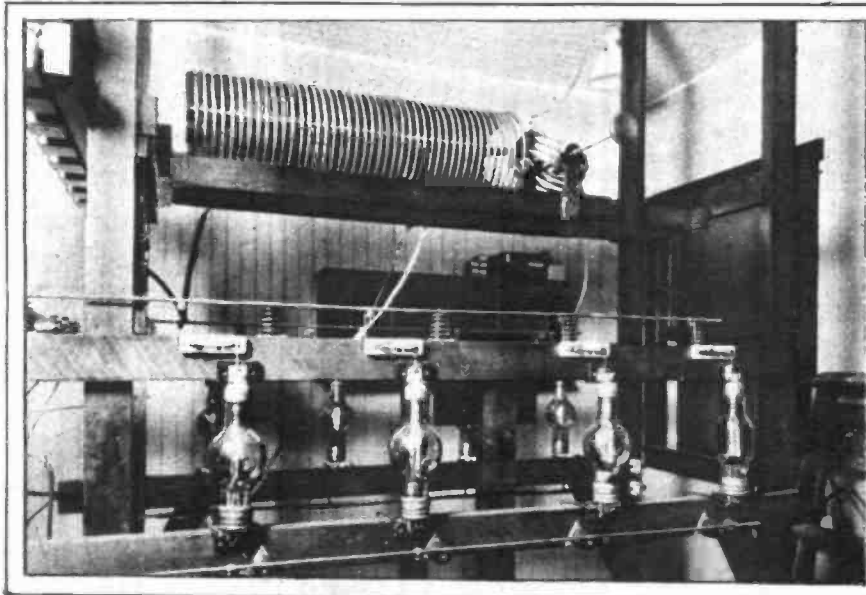

View of part of transmission equipment at WTAM

(Continued on Page 46)

Radio is Now a Billion Dollar Business

A few weeks ago, station WDAR, Lit Brothers in Philadelphia, invited F. N. Supplee, General Representative of Radio in the Home, to give a talk from their station outlining the results of a long series of investigations he has been making in the radio industry.

Let me say in the first place that F. N. is not a radio fan and was decidedly anything but a radio fan when I first met him. F. N.'s idea of a good time is to count up his "prospects" and find that they are rated well into the millions of dollars. When that result appears on the paper before him, the sun starts to shine and the birds begin to sing and the flowers open up and life is worth living. But life is not worth living to him unless he can count up at least to one hundred million dollars.

Therefore, it is most gratifying to me personally to find that since his investigations, F. N. has begun to speak respectfully about radio. It proves to me, not that radio is a wonderful hobby nor a great science nor a fine method of home entertainment because I knew all of these things, but it proves one thing that I was not quite sure of and that is that radio is on such a solid and substantial financial basis that it is worth while to continue to make sets and sell sets and buy sets—and incidentally to publish a radio magazine.

I am reprinting F. N.'s radio speech here at the request of a great many listeners-in who heard it and wanted to have the facts which he gave them in such shape that they could preserve them for future reference.
H. M. N.



The top picture shows F. N. Supplee before he discovered the one billion, nine hundred million dollars that radio represents. And then came the billion dollar smile you see in his picture on the left

IT SEEMS that it is going to be quite a job to condense into a twenty-five-minute talk even the high lights of the work of even months, for five of which I have been connected with *Radio in the Home*, and six months before I had the privilege of that connection; but I will do the best I can.

My introduction into the radio field came through reading a little booklet in which the following names were mentioned:

- American Telephone and Telegraph Co.
- General Electric Co.
- Westinghouse Electric and Manufacturing Co.
- Western Electric Co.
- Radio Corporation of America.

I am nothing but a lay citizen; I am neither a radio fan, a radio golfer or, worse than that, a radio nut; in fact, I do not know more than three technical terms in radio. I am not "sold" on radio and yet I believe it is the greatest thing that has ever come into the world for its pleasure and enjoyment.

Whenever I go into a movie the first thought that comes to my mind is the tremendous cost—cost in money, cost in labor, cost in preparation, cost in thought of de-

tail—and I believe that in recent years the whole world has looked upon the movie industry as the acme of expenditure in the production of pleasure. But I will lay before you a few facts and let you judge between radio and the movies, judging on the same basis of the cost in money, labor, preparation and detail.

There are now in this country nearly six hundred stations for broadcasting purposes, the total construction of which represents a greater expenditure than one hundred million dollars; and many of these stations cost on an average of fifty thousand dollars a year to operate. If all of these stations cost fifty thousand dollars a year to operate, it would mean a total expenditure for your pleasure and for mine of thirty million dollars a year.

In two years' time this money has been expended, these stations have come into existence to bring pleasure to the "listening-in" public, which comprises approximately one-tenth of the population of this

country. This is a greater movement than has ever occurred in any other similar merchandising enterprise. This nine to ten millions of population has paid out in hard cold cash one hundred million dollars for apparatus to receive the concerts given by these six hundred stations.

The most of this apparatus has been manufactured by seventy-five rated concerns. There are lots of unknown quantities in the radio manufacturing field; there are lots of very poor products on the radio market. But we as a publication are interested only in the seventy-five rated manufacturers, whose combined capital represents the grand sum total at the present time of one billion, nine hundred million dollars. Even in today's big figures, these figures loom tremendously large.

Now let us visit some of the broadcasting stations. I would like to have the privilege of taking you through all that I have seen, going into details of their construction and decoration, the type of men who operate them, the concerns who are back of them—but time is too limited; we will only touch on the headliners in the broadcasting industry.

Chief among these is the American Telephone and Telegraph Company, 195 Broadway, New York, on the fourth floor of the building belonging to that same



Left, Hotel Statler, Buffalo, the Federal Telegraph & Telephone Co., Station WGR.

Right, three big men of the Radio Corporation of America; O. D. Young, Chairman of the Board, Dr. Alfred N. Goldsmith, Director of Research, and Gen. James G. Harbord, President of the Corporation.



wonderful company. This station to the radio fan is known as Station WEAF.

Here one hundred and fifty-five employes labor exclusively for you and me to find out what kind of radio is wanted in the home. And after they have found out what is wanted, they try to determine (from the great mass that is wanted) what will give pleasure to the greatest number, and how it should be given to please the majority, and who should give it that it will be most pleasing, and at what hour the most of the listeners will be "listening-in."

It is quite some task preparing programs for a nine or ten million audience. It is some task to prepare programs which must give pleasure through the ear only; it is much easier to prepare amusement which is seen through the eye rather than heard through the ear, therefore much greater is the task of broadcasting for radio in the home.

Another wonderful thing about radio broadcasting is its cleanliness, because all programs are government inspected.

We have a wide variety of sub-



jects. The major things to be decided are: If it is music, shall it be instrumental or vocal, shall it be classical, religious or jazz; when shall literature, scientific or religious subjects be given; when shall talks on education, hygiene or finance be most appreciated; what is the best news to give, covering sports, the daily high lights, events, elections—national, state or local; then the commercial side of life—interests in manufacturing, merchandising or raw products—shall they be considered?

Personally I am interested in two phases of radio reception from broadcasting: to go to church without going, and to enjoy a prize fight without paying the price! In this latter thing, I had the privilege of "listening-in" for the first time when the Firpo-Willard fight was pulled, and one could almost hear each blow struck because the announcer at the ringside was clever.

Radio is a wonderful thing to bring the whole world to you in the comfort and exclusiveness of the home.

The greatest thing that is facing the broadcasting industry today is what faced the talking machine

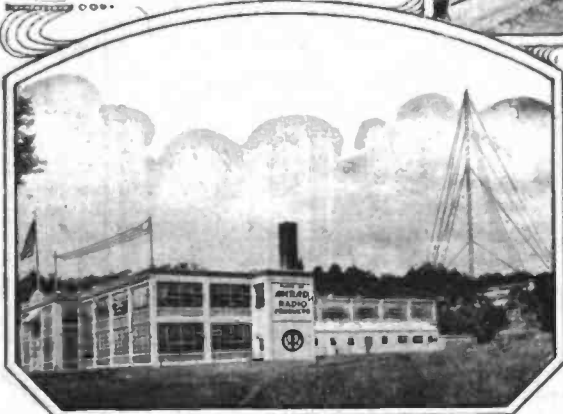

Above is "Radio Central," WJZ, on Aeolian Hall, New York

Left—Amrad factory and broadcasting station WGI at Medford Hillside, Mass. Right—The Union Trust Co. of Cleveland, Ohio, Station WJAX



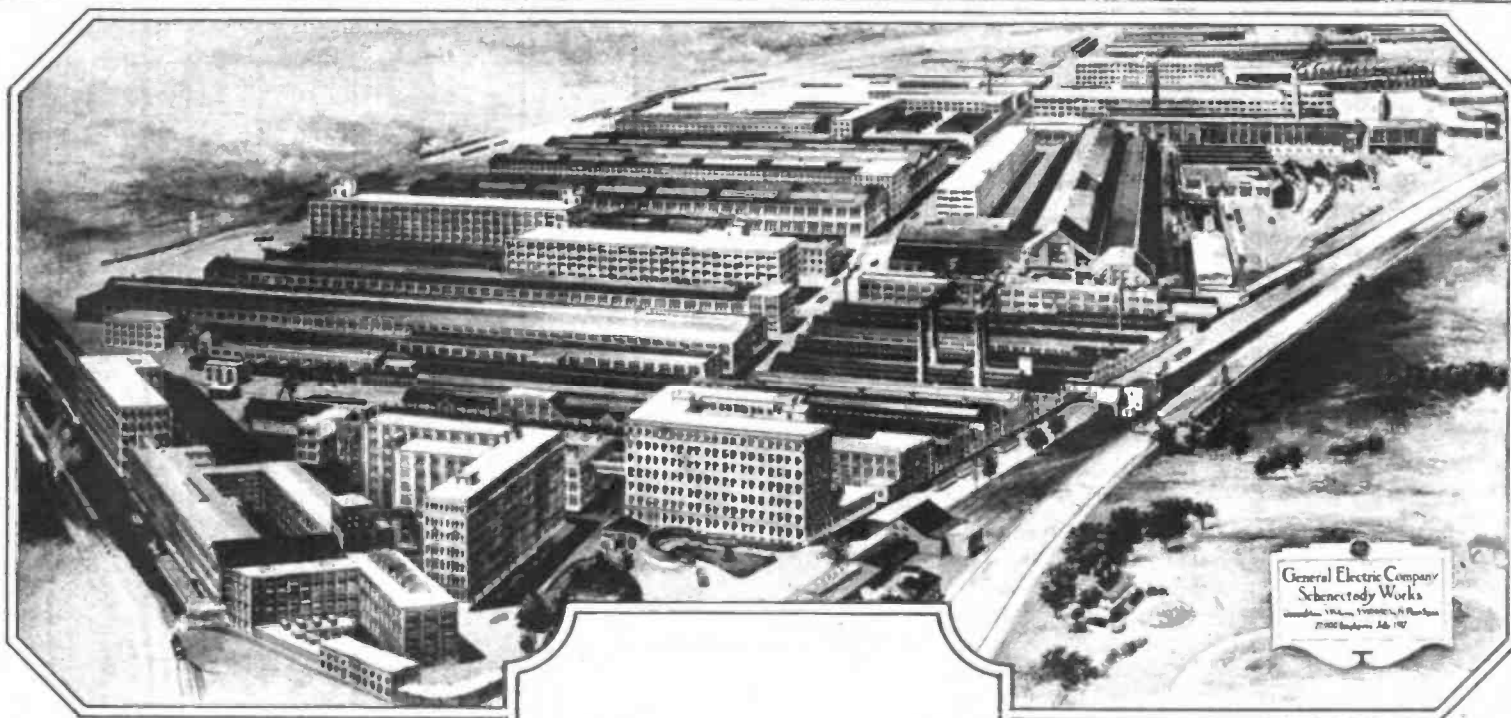

General Electric Company
Schenectady Works
Schenectady, N. Y.
1902-1903

Above, the great works of the General Electric Company at Schenectady. Center, the beautiful building of the American Telephone and Telegraph Company and the Western Electric Company at 195 Broadway, New York

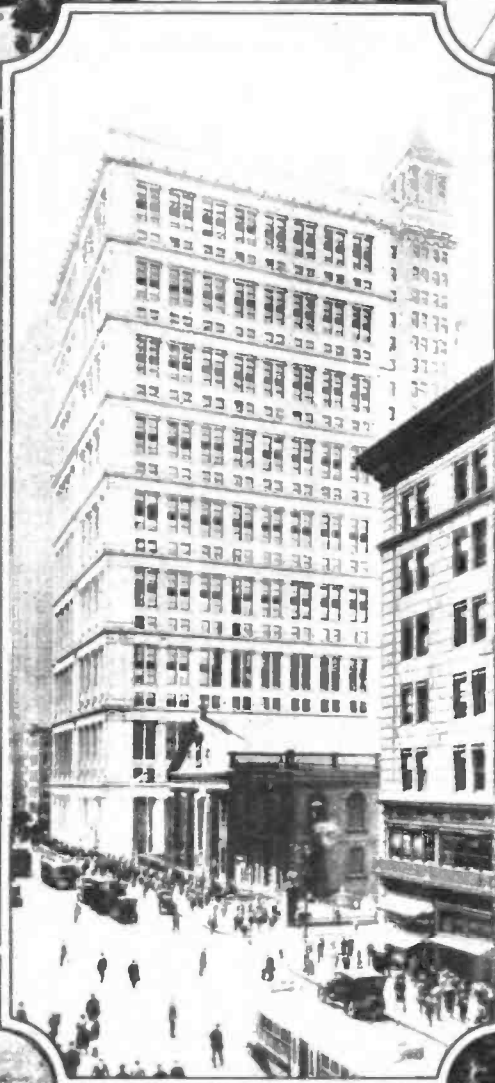

speech. Some thought we should have broadcast the funeral service, but because radio is not appreciated, up to the present time, in its full usefulness, we felt that a great mass of the people might consider us disrespectful to his memory, and because our first object is to please the great mass of the American public, we did not broadcast his funeral service."

Read these few lines again and again and get the full import of this thoughtfulness.

Now an interesting bit of data about Station WEAJ is that there are direct telephone lines to Station WMAF, which is owned by the Round Hills Radio Corporation, at South Dartmouth, Mass.; and Round Hills Radio Corporation is practically owned by Colonel Green, son of the late well-known financier, Mrs. Hetty Green. This company pays the American Telephone and Telegraph Company to relay their concerts through its station for the benefit of local "listeners-in."

The next station to which wires are laid is WCAP, the Chesapeake and Potomac Telephone Company of Washington, D. C.

(Continued on Page 43)

Below, the huge plant of the Westinghouse Electric and Manufacturing Company at E. Pittsburgh, Pa.

industry in its infancy and the movie industry in its infancy—the question of headliners or artists. Both of the aforementioned industries have these artists. But how these artists can be obtained for the benefit of "listeners-in" through radio, and be paid for their services, is one of the stupendous problems facing this great industry. However, there are movements under way which we hope in the near future will, to a large extent, solve part of this great problem.

To give you a little insight into the type of men who are leaders in this remarkable industry, let's you and I pay a visit to Mr. Griswold, vice president of the American Telephone and Telegraph Company. Let us open the doors and you come with me and see him rise from behind his desk, see him step across the room to greet us, feel the clasp of his hand-shake, see that wonderful smile, and listen to just this one item in all his talk.

"In the interest of the American public, we broadcast Mr. Harding's

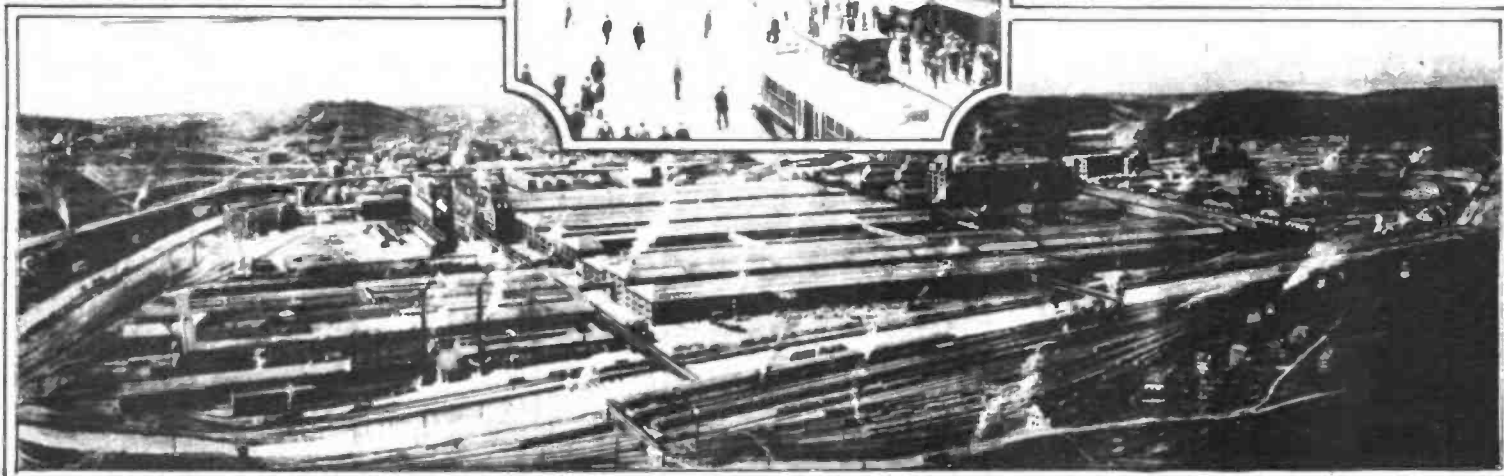

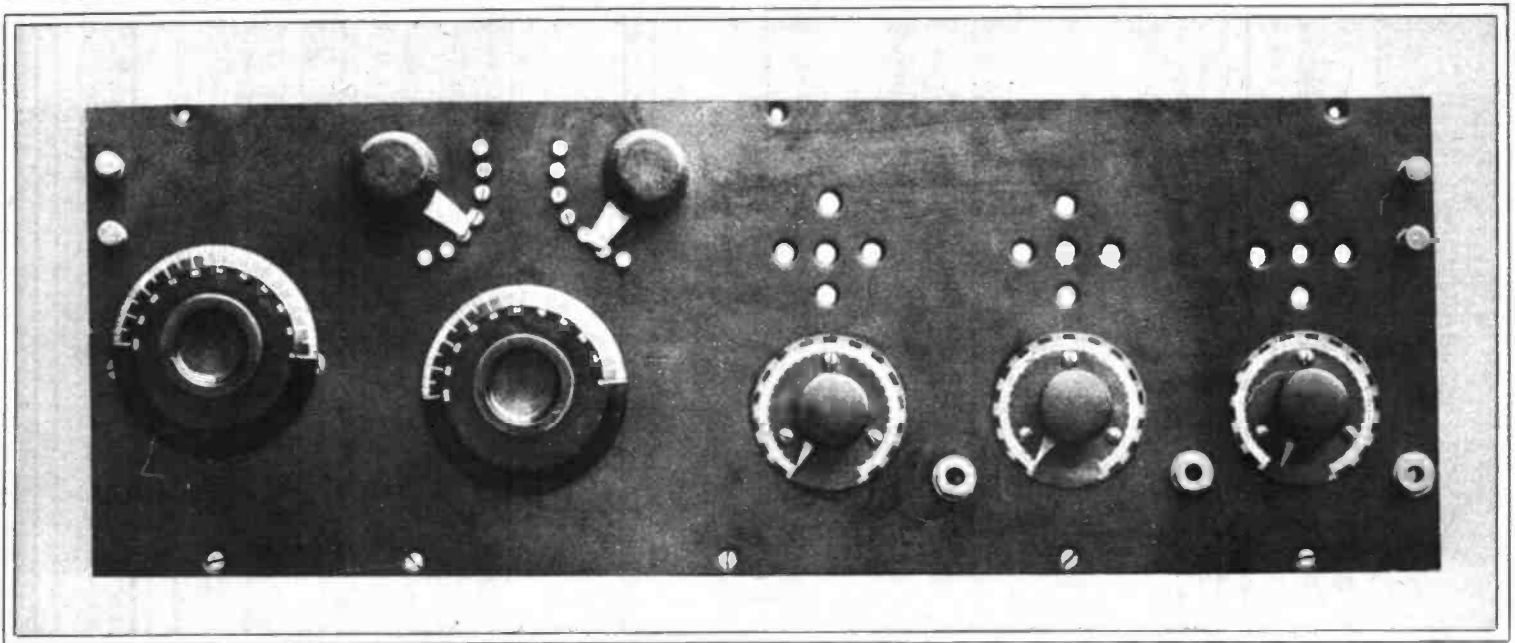

The Gibbons With a Variocoupler

IN THE August issue of this magazine, I gave a hook-up which is popularly known as the Gibbons, employing a variometer as the principal tuning device. The letters received in this office since then have proved what a very popular and efficient set this has turned out to be and many questions have come in asking whether other instruments cannot be used in place of the variometer. So many fans seem to have almost all of the material required outside of the variometer that it has been interesting to me to experiment to see how many tuning arrangements can be used.

As a matter of fact, that entire hook-up can be used with almost any kind of coil in place of the variometer. Even a 75-turn honeycomb coil or forty or fifty turns of wire around a salt box or a coil of any kind can be used there and the remainder of the hook-up stands exactly as it was in that issue.

The particular question which has

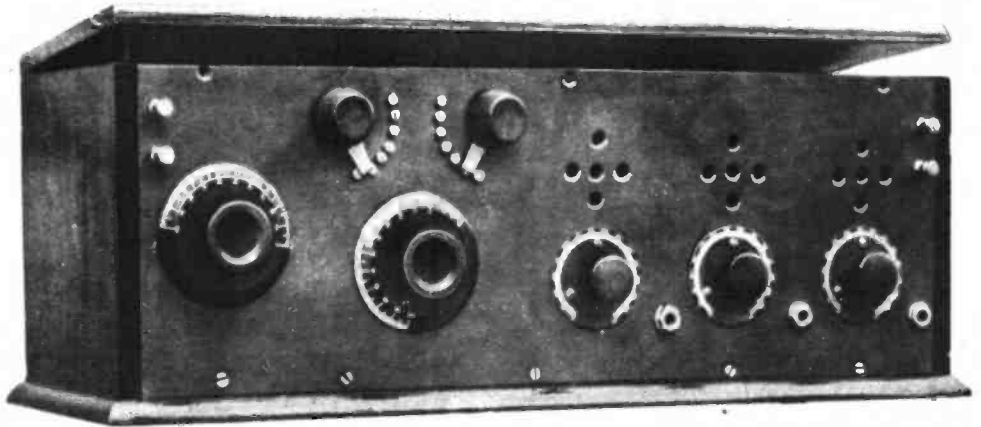

At the top of the page is the front panel, 7 inches high by 20 inches long, showing the layout of the apparatus. Above is the completed set in its cabinet, and below, a view showing the instruments as arranged on the baseboard

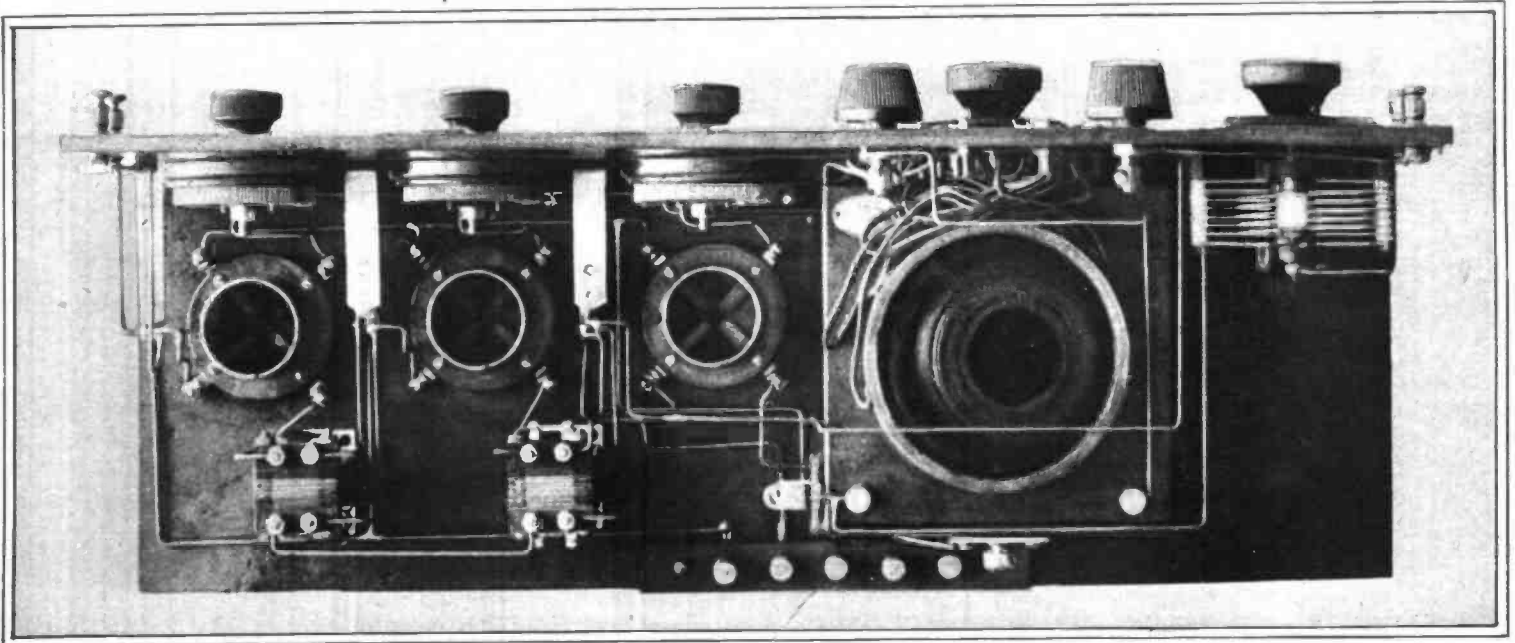

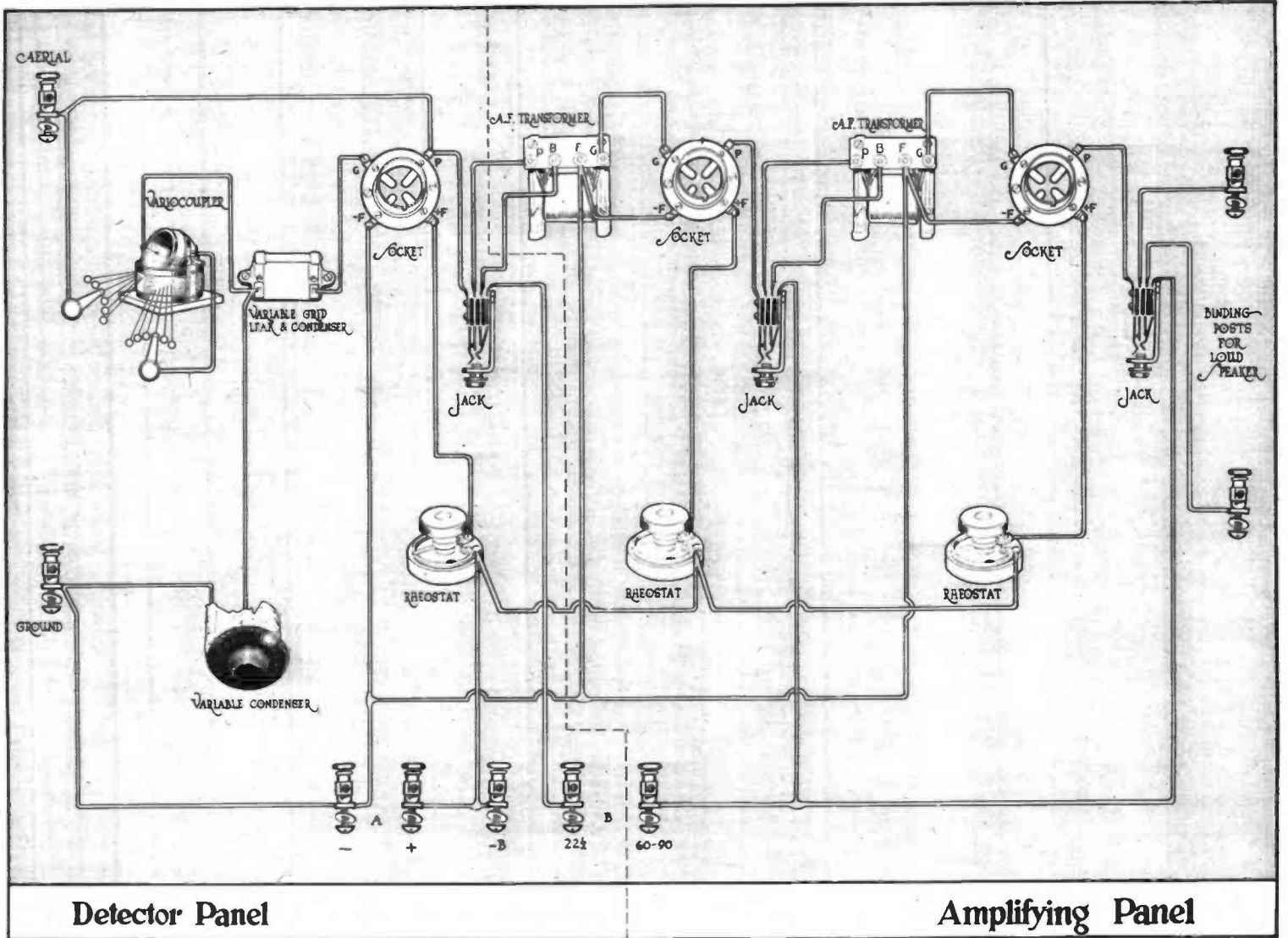

Detector Panel

Amplifying Panel

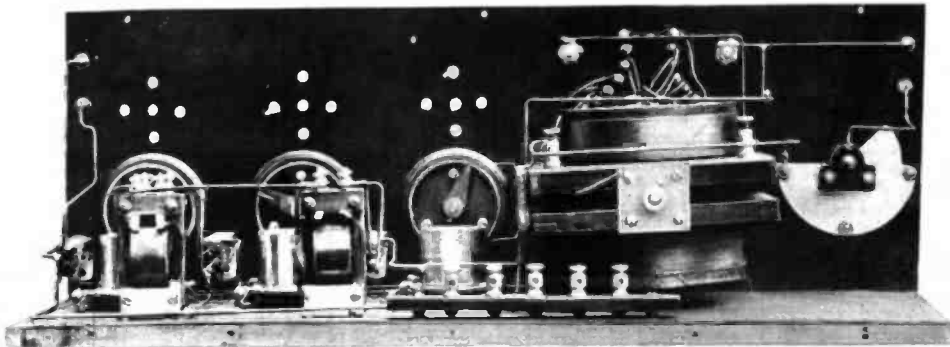

brought about this present article, however, was asked by the secretary and treasurer of this company, Mr. G. W. Kraft, who had a "single-circuit regenerative" set with two steps of amplification already mounted on a panel and enclosed in a cabinet. Those of you who saw the article about this circuit in the June issue will remember the set. We presented this to Mr. Kraft after it was made up and photographed for our magazine.

With the new wave lengths, however, Mr. Kraft, like many others who use the single-circuit regenerative set, found that it was very efficient in getting loud signals

(Continued on Page 46)

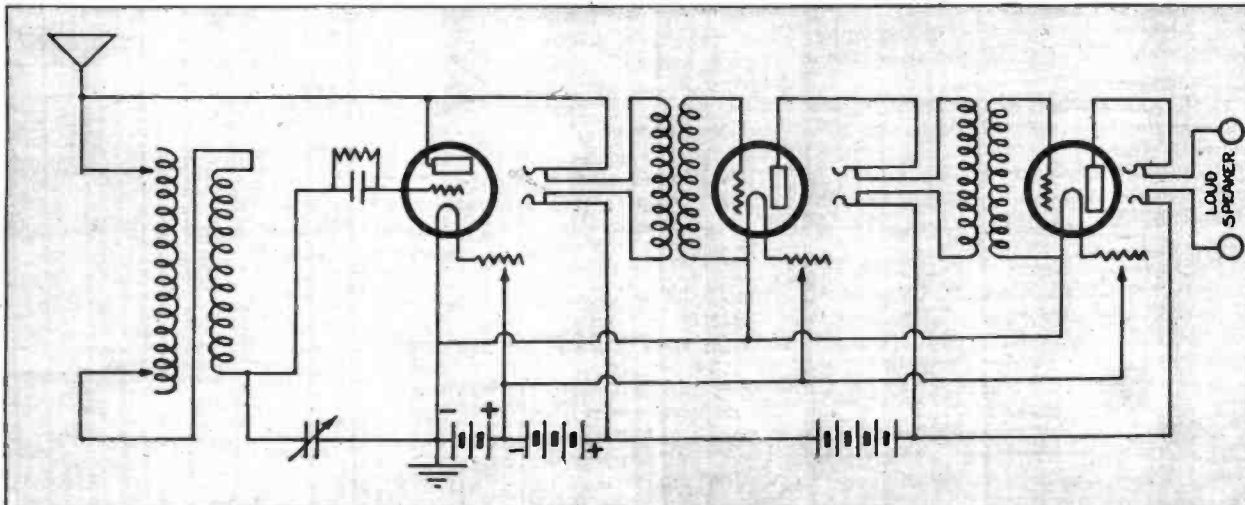

At the top is a "picture" diagram of the hookup. Center, a back view showing arrangement. Left, the usual symbol diagram of the hookup



Is The Radio Market Saturated?

YOU will hear many people, in discussing radio, say that they think the market is very rapidly becoming saturated. Look at this photograph. What does it indicate to you?

The picture was made in front of the Radio Sales Studio in Washington, D. C., on the night of the Dempsey-Firpo fight. The returns were brought directly from the ringside through Station WJZ, in New York, and Station WRC, in Washington, both broadcasting stations of the Radio Corporation of America.

For hours this immense crowd stood in front of the store waiting for the main event to come through.

If these people had had radio sets in their own homes, do you suppose that they would have endured the discomfort of waiting this way in order to get returns from the fight?

The fact that they were there at the time the photographer sprang his flashlight proves that not one of them had an efficient radio set in his own home.

And, if you will look at the photograph very carefully, you will see that this remark should not be made only with the pronoun of the masculine gender. Careful count of the original negative showed that there were seventy-four women visible in the crowd. This, of course, does not take into consideration the number who must have been hidden in this dense mass of humanity.

The representative of *Radio in the Home* was in Rochester on this night. He reports that vast crowds stood in front of all the newspaper offices for hours to hear the result of the contest.

Does that indicate that the radio market is saturated?

It does not. On the contrary, it indicates that, with the growth of broadcasting of such events as this, every one in the above photograph and every one of the people in Rochester and every one of the thousands and thousands of people in every city all over the country who did exactly the same thing on that night, will be more than anxious to possess radio sets of their own.

Every one of them is a "prospect" who is already "sold" on radio as a home necessity.

The radio market will not be saturated until our streets are empty every time there is a great event going on anywhere in the world. It will not be saturated until everybody is at home in front of his own radio set getting the results at first hand and without the bother of waiting in discomfort, and possibly in bad weather, in the open streets of the city.

And when I see a photograph like this, showing a great crowd in front of a store, I am forced to ask myself the question, "What is the average radio dealer doing to satisfy the real wants of these people?"

Such a store as is shown in this picture is doing the thing in the right way; it is gathering and showing only radio apparatus of the highest quality and is specializing among its customers only in the kind of people who can buy a radio set without having to wait for Saturday night.

But is the average radio dealer throughout the United States doing this thing? Has he the vision to see the trend of radio as it is at the present time, or is he simply passing across the counter the kind of stuff that meets ready sale with the cheapest people and letting the morrow take care of itself?

The man who will buy anything or everything without question never has made a permanent success of any merchandising campaign and never will. The man who is particular to find out what he wants and to insist upon only that and not something "just as good" is the man whom it is a little more trouble to serve but whom it is vastly more profitable to have upon one's books.

Radio must get after this class of people. It must stop selling oatmeal boxes and spools of wire to people who have to borrow the price to pay for them and it must specialize in the good-looking stuff which appeals to the people who are a little harder to sell, but who are more permanently and much more profitably "sold," once they have been won over.

Radio Fan Gives Baseball Bugs Treat



G. H. Fromann, of New York, is a dyed-in-the-wool radiophan and doesn't care who knows it! He decided to start the worlds series baseball games right, and equipping his Rolls Royce with a receiving loop set and Western Electric loudspeaker, he drove through town, finally landing in a vacant lot back of the Stadium where an overflow crowd had gathered. Here he tuned in WEAJ and the crowd enjoyed the broadcast play-by-play report of the game.

Photo Copyright Western Electric Co.

Super-Heterodyne

(Continued From Page 14)

the United States. The log in this article gives you only a few of the various stations received and shows the various directions of the compass covered.

It must be admitted that the super-

heterodyne circuit is somewhat difficult to tune at first. Gradually, however, as one becomes accustomed in his early days to its manipulation, he begins to see that there are certain adjustments that are easy to make, and after that it really becomes only a two-control set.

I now find it about the simplest and most easily controlled outfit that I know of.

One Week's Log on Super-Heterodyne

Radio log on eight-tube super-heterodyne by Birchall Hammer, received in one hour's time each night; stations under 100 miles not recorded:

MONDAY					
260 miles—	WCAE	Pittsburgh, Pa.	Clear on Magnavox	High vol.	1 stg. det.
260 "	KDKA	"	" " " "	" "	" " 1 stg.
700 "	WDAP	Chicago, Ill.	" " " "	" "	" " 2 stg.
275 "	WBAB	Syracuse, N. Y.	" " " "	" "	" " 1 stg.
950 "	WPO	Memphis, Tenn.	" " Head Pns.	" "	" " 2 stg.
675 "	WSB	Atlanta, Ga.	" " Magnavox	" "	" " 2 stg.
125 "	WEAS	Washington, D.C.	" " " "	Low "	" " 2 stg.
TUESDAY					
100 miles—	WEAF	New York City	Clear on Magnavox	High vol.	det.
300 "	WNAC	Boston, Mass.	Stat.	Low "	" " 1 stg.
700 "	WDAC	Springfield, Ill.	" " " "	" "	" " 2 stg.
450 "	WBT	Charlotte, N. C.	Clear on Magnavox	" "	" " 2 stg.
1450 "	WCAT	Rapid City, S. D.	" " Head Pns.	" "	" " 1 stg.
1225 "	PWX	Havana, Cuba	" " " "	" "	" " 1 stg.
100 "	WOR	Newark, N. J.	" " Magnavox	High "	det.
1910 "	KZN	Salt Lake City	Stat. " Head Pns.	2nd stg.	" "
WEDNESDAY					
400 miles—	WAAD	Cincinnati, O.	Clear on Magnavox	High vol.	1 stg.
250 "	WBZ	Springfield, Mass.	" " " "	" "	" " 2 stg.
300 "	WGR	Buffalo, N. Y.	" " " "	" "	" " 2 stg.
275 "	WFAB	Syracuse, N. Y.	" " " "	Low "	" " 2 stg.
225 "	WGY	Schenectady, N.Y.	" " " "	High "	" " 1 stg.
225 "	WHAZ	Troy, N. Y.	" " " "	" "	" " 1 stg.
1325 "	PWX	Havana, Cuba	" " " "	Low "	" " 2 stg.
700 "	WDAP	Chicago, Ill.	" " " "	High "	det.
250 "	WGI	Medford Hills, Mass.	" " " "	Low "	" " 2 stg.
THURSDAY					
100 miles—	WEAF	New York City	Clear—Interference	by spark	" "
260 "	KDKA	Pittsburgh, Pa.	Clear on Magnavox	High vol.	1 stg.
675 "	WSB	Atlanta, Ga.	" " " "	Low "	" " 2 stg.
550 "	WHAS	Louisville, Ky.	" " Head Pns.	" "	" " 1 stg.
950 "	WKN	Memphis, Tenn.	Stat. " aud., clear on det.	" "	" "
400 "	WLW	Cincinnati, O.	" " " weak "	" "	" "
FRIDAY					
260 miles—	KDKA	Pittsburgh, Pa.	Clear on Magnavox	High vol.	1 stg.
675 "	WSB	Atlanta, Ga.	Static	" "	" "
100 "	WEAF	New York City	Clear on Magnavox	High vol.	1 stg.
1910 "	KDYL	Salt Lake City	Static low aud.	" "	" "
2275 "	KWH	Los Angeles, Cal.	Loud stat. & bdct., Head Pns.	2d stg.	" "
SATURDAY					
260 miles—	WCAE	Pittsburgh, Pa.	Clear on Magnavox	High vol.	1 stg.
360 "	WGAM	Cleveland, O.	" " " "	" "	" " 1 stg.
250 "	WBZ	Springfield, Mass.	" " " "	" "	" " 1 stg.
225 "	WGY	Schenectady, N.Y.	" " " "	" "	det.
1075 "	WPAM	Topeka, Kan.	Stat. with high volume.	2 stg.	" "
260 "	WJAR	Providence, R. I.	Clear on Magnavox	High vol.	2 stg.
100 "	WJZ	New York City	" " " "	" "	" " 1 stg.
675 "	WSB	Atlanta, Ga.	" " " "	" "	" " 2 stg.
700 "	WDAP	Chicago, Ill.	" " " "	" "	" " 1 stg.
SUNDAY					
1050 miles—	WHB	Kansas City, Mo.	Clear on Magnavox	High vol.	2 stg.
100 "	WJZ	New York City	" " " "	" "	" " 1 stg.
700 "	WDAP	Chicago, Ill.	" " " "	" "	" " 1 stg.
360 "	WGO	Cleveland, O.	" " " "	" "	" " 1 stg.
1210 "	WFAA	Dallas, Tex.	" " " "	" "	" " 2 stg.
875 "	WOC	Davenport, Ia.	" " " "	" "	" " 1 stg.
825 "	WCBD	Zion City, Ill.	" " " "	" "	" " 1 stg.



Doing away with the unsightly antenna

Look at the roofs.

Cluttered with flimsy antennae that spoil the appearance of houses.

The Dubilier Ducon (socket-plug) does away with the unsightly antenna. Also with lightning arresters and other protective devices.

Simply screw the Ducon in a lamp-socket and connect it with the receiving set. The broadcasting stations come in strong and clear.

Besides, tuning is sharper with the Ducon than with an antenna, and static is reduced.

Price \$1.50. At all good dealers

DUBILIER CONDENSER & RADIO CORP.

48-50 West Fourth Street

New York

DUBILIER DEVICES



DUBILIER MICADON Fixed Condenser



DUBILIER DURATRAN Radio Frequency Transformer



DUBILIER VARIADON Mica Variable Condenser

and Telegraph Company to determine the possibilities of radio broadcasting. This company connects through its wires and those of its associated and connecting companies some 15,000,000 telephones distributed in all parts of the United States.

Long before the days of radio broadcasting the future of the vacuum tube as an adjunct to the telephone appealed to the engineers of the company.

They launched upon intensive development of the freakish, uncertain vacuum tube until it became a reliable, standardized unit. It was advanced to this stage of development in sufficient time to be of immense value to the American forces in the World War. Most of the aircraft radio telephones which had such a salutary effect on the conduct of aerial warfare were developed and manufactured by the Western Electric Company of the Bell System.

The vacuum tube plays an important part in the long-distance telephone service. With the aid of vacuum tube repeater stations along the route it is now possible to speak from Havana, Cuba, to the Catalina Islands in the Pacific with the clear speech of good volume.

When radio broadcasting sprang into prominence, the company was approached by many firms who desired to erect broadcasting stations for their own use. It was soon recognized that if even a limited number of these requests were complied with an ethereal chaos would result. If an amicable arrangement for division of time "on the air" were made among the many who proposed to broadcast, each would find their schedules so limited that they would realize but little on their investment.

In view of this situation, the American Telephone and Telegraph Company decided to erect one broadcasting station of the very highest grade in New York City, available to any one who has a message of real interest and value to the radio audience. The quality of programs offered by this station—WEAF—has created a large and loyal audience. The artists appearing on its programs are carefully selected and each contributes to a well-balanced program.

Recently WEAF began operating from new studios at 195 Broadway, New York.

Programs for radio broadcasting rendered at WEAF's studios are now being sent out not only through that station in New York City, but frequently through WCAP in Washington, D. C., and WMAF at South Dartmouth, Mass. WEAF transmits on a wave length of 492 meters (610 kilocycles); WCAP in Washington, D. C., operated by the Chesapeake and Potomac Telephone Company, transmits on 469 meters (640 kilocycles), and WMAF, South Dartmouth, Mass., the Round Hills Radio Corporation station, transmits on a wave length of 360 meters (833 kilocycles).

Broadcasting through three stations on a regular schedule is only one of the phases of the company's investigation of the possibilities of radio broadcasting. Its programs for WEAF have been picked up from points as distant as Chicago, St. Louis and Kansas City and transmitted by long-distance telephone lines to New York City.

A special effort is being made to determine the preferences of the radio audience with regard to programs. Every suggestion, criticism and expression of approval is carefully tabulated in statistics which are used as a guide in arranging the broadcasting programs. The skill with which pro-

WEAF

(Continued From Page 5)

grams involving the use of many musical instruments, such as the Capitol Theatre, have been picked up and broadcast, and the wide variety of programs offered have given WEAF an enthusiastic radio following.

Consequently, when Colonel E. H. R. Green decided to give New England the highest grade of radio programs, he sought a means of securing WEAF's programs for his own station. Arrangements were consummated to send these by special long-distance circuits to South Dartmouth in order to operate the 500-watt West-

plex than it appears to one unfamiliar with the subject. A telephone line suitable for ordinary commercial speech is usually totally unfit to handle the wide range of frequencies required by radio broadcasting. Furthermore, that which is received at the terminus of the long-distance lines for radio purposes is immensely amplified by a series of vacuum tubes. As a result, the slightest "line noise" is immensely amplified and broadcast. For this reason special means are necessary, requiring the use of extensive apparatus and the services of skilled engineers before a line is in condition

AMERICAN TELEPHONE AND TELEGRAPH COMPANY
RADIO BROADCASTING STATION WEAF
195 BROADWAY, NEW YORK, N. Y.

PROGRAM DEPARTMENT

1. What type and make of radio set are you using? _____
2. What size and type of aerial are you using? _____
3. What radio broadcasting stations do you hear?
 a. _____ d. _____ g. _____
 b. _____ e. _____ h. _____
 c. _____ f. _____ i. _____
4. How many ordinarily listen in? _____
5. How many in the family: Adults Male _____ Children Boys _____
 Female _____ Girls _____
6. Occupation: Professional? _____ Merchant? _____
 Mechanic? _____ Office? _____ Stenographer? _____
7. Residence: State of _____ City? _____ Town? _____
 Suburb? _____ Farm? _____
8. Do you own your own home: Single House? _____
 Two Family House? _____ Apartment Building? _____
9. Do you rent or lease: Single House? _____
 Two Family House? _____ Apartment? _____
10. Have you a telephone? _____
11. Is your house wired for electric lights? _____
12. Do you own an automobile? _____ Piano? _____ Player Piano? _____
 Phonograph? _____ Other Musical Instruments? _____
13. Are you interested in golf? _____ Tennis? _____
 Baseball? _____ Football? _____ Boxing? _____
 Swimming? _____ Boating? _____ Fishing? _____
 Camping? _____ Hunting? _____ Photography? _____
 Other Sports? _____
14. What periodicals do you read? a. _____
 b. _____ d. _____
 c. _____ e. _____
15. Do you patronize the Public Library? _____ Circulating Library? _____
16. Upon what particular subject would you like to hear interesting, instructive or entertaining talks? _____

This questionnaire has been sent out to a great many thousand listeners-in by Station WEAF in order to analyze the radio public.

ern Electric transmitter which the colonel has erected on his estate.

New York is the center of artistic talent and has a greater variety of program matter available than any point on the continent. It is possible that New York will become the center for the gathering of radio programs for broadcasting from stations in distant cities which may be connected by wire telephone lines with studios in New York. Already the studios at WEAF are supplying a third station, that of the Chesapeake and Potomac Telephone Company in Washington.

The task of sending programs by wire telephone is somewhat more com-

suitable for use in connection with broadcasting.

The magnitude of the task of preparing telephone lines so that they may be used in connection with broadcasting is indicated by the fact that no fewer than sixty-five telephone and radio engineers were required to operate the telephone lines and their connections with the radio stations on the recent occasion when a program rendered at Carnegie Hall by the National Electric Light Association was broadcast simultaneously by stations WEAF, WGY, KDKA and KYW in New York City, Schenectady, Pittsburgh and Chicago, respectively.

Many radio fans who are able to receive the three stations now using WEAF's programs have noted that the quality of transmission from the stations most distant from WEAF is just as good as that heard from WEAF itself.

In its extensive investigation of the possibilities of radio broadcasting, the company has been making a special analysis of all correspondence received from the radio audience. Not only is every letter read and personally answered as it comes in to the station, but every fact which can be gleaned from it is carefully tabulated so that eventually complete information as to the size, distribution and characteristics of the radio audience will be available.

A force of readers and statisticians is constantly employed in accumulating the figures. Not only is the name and address of every writer recorded, but two kinds of facts are gathered:

First, every preference with regard to program, whether it be a suggestion, criticism or expression of appreciation, is carefully tabulated. By means of these figures the audience's preferences with regard to programs are accurately determined. A correct balance of educational matter, popular music, dance music, classical music, instrumental selections and sporting features are obtained. These are used for the guidance of WEAF's program department in planning each day's features.

Second, another set of figures are being collected to determine the geographic distribution of the radio audience, the average age, sex, intelligence of the radio listener and other special facts which the letters indicate.

WEAF frequently has features on its programs which are experiments for determining the desires of the radio audience. For instance, a series of lectures offered by the staff of Columbia University co-operating with the company has just been completed. Some time ago WEAF began the experiment of broadcasting a special program of one hour's duration from 11:00 to 12:00 in the morning. The surprisingly large response from the morning hours exceeded the expectations of every one concerned. A special program for women is rendered each Thursday morning, and the kind of correspondence received in connection with it indicates a very large and responsive audience at this time of the day.

The thoroughness with which the company is studying the problem of radio broadcasting is indicated by the extensive staff which it employs. More than fifty-seven are required to maintain the station and to conduct the extensive statistical and experimental work being carried on.

Mr. E. S. Bloom, vice president in charge of radio, recently told of the company's work in this line. He said:

"The American Telephone and Telegraph Company began broadcasting on July 25, 1922, on 360-meter wave length, being on the air twelve hours weekly. On October 2, 1922, we changed to 400-meter wave length.

"Our early programs contained a certain amount of mechanical music, but since October, 1922, when we began broadcasting on 400 meters, no mechanical music has been used. Our programs have been gradually developed and improved as we have gained experience and become more fully acquainted with the desires of the radio public.

"During the nine months that we have broadcast, nearly two hundred of America's leading statesmen and citizens have spoken to you through

up, we recommended the Death Valley and we have also had great success with the Multi-Point Hi-Power. Both these crystals require a very light touch with the cat whisker. For a semi-fixed point, we liked the Silver-tone about as well as any.

I asked Ted Vollten to write out complete wiring directions, and here is what he has to say:

Take a three-sixteenth-inch bakelite panel eighteen inches long and seven inches high and lay out the following apparatus on it:

In the upper left-hand corner is the variocoupler for tuning and next to this is a twenty-three-plate variable condenser, then next to this is an eleven-plate variable condenser. Between these two condensers there is the crystal detector which can be mounted, placed evenly between the two dials and a little above them. This is in case you are using some crystal other than the Erla.

To the right of the eleven-plate variable condenser we have the first double circuit jack which controls the first amplifying tube and next to this on the right we have the last single-circuit jack which controls the second stage of amplification. Then lay off in the bottom left-hand corner of the panel the switch knobs which control the number of turns on the primary of the variocoupler. Each of these switch levers has six contacts from the primary of the variocoupler.

Then next to these two switch levers on the right we have a rheostat which controls the filament for the radio frequency tubes and next to this we have another rheostat which controls the filament of the amplifier tube, and then on the lower righthand corner we have a battery switch for disconnecting the filament battery.

When you lay off a panel to mount these different pieces of apparatus on it, be sure that you have them all in line—that is, looking across the panel

Erla Three-Tube Reflex Circuit

(Continued From Page 14)

at the top you will find that the coupler and the variable condensers are all in a line with each other and are not "staggered," which would make the panel look not symmetrical. The lower line of rheostats and switch levers are also in the same straight line, which keeps the panel looking as though it was laid out by a mechanic and not a novice.

Then cut a baseboard 17 inches long by 8 inches deep by one-half inch thick and smooth the edges and give it one or two coats of orange shellac and screw with four wood screws this baseboard at the bottom of the panel so as to make a right angle between the panel and the baseboard.

Now for the laying out of the transformers and tube sockets on this baseboard.

If you look at the photograph that shows the top view looking down on to the baseboard you will find that in the center of the baseboard on the left-hand side we have two binding posts. These binding posts are for the antenna and ground connections. Then on the opposite side of the panel in the center you find we have four binding posts. Two binding posts are for the filament or A battery and two for the B battery.

As close to the variocoupler as you can put it, place the first tube socket and then behind and to the right of this first tube socket there is another tube socket that holds the Erla reflex radio frequency transformer.

Then on the same line with the first tube socket, to the right of the socket that holds the transformer, place another tube socket, which is the socket for the second tube, then behind this and to the right is the second socket

that holds the second radio frequency reflex transformer. Then in the same line with the other tube sockets place the third tube socket a little to the right of the second radio reflex transformer socket.

A good way to lay off these sockets so that you can get them right is to let the sockets overlap each other on the corners about three-sixteenths of an inch.

Looking down on top of the sockets from the top of the set, the first tube socket should have the slot that the tube goes into toward the rear. That will bring the connections on the tube sockets in this manner: to the rear of the set on the left is the grid. Then to the right to the rear is the plate post marked "P." Then the first radio frequency transformer socket should be about three-sixteenths of an inch along side.

The second tube socket should be placed the same as the first and so the plus F post of the first radio frequency transformer socket is next to the G post of the second tube socket. Then the plate post of the second tube socket is next to the F minus post on the second radio frequency socket. By overlapping these sockets about three-sixteenths of an inch, you can run extremely short leads from the plate post to the minus filament on the transformer socket and from the plus filament post to the grid on the tube socket.

After these tube sockets have been placed on the baseboard and screwed down, you can install the audio frequency transformers. Place one along side of the second radio frequency transformer socket, then to the front and right of this radio frequency

transformer place the other, at right angles and to the right of the third tube socket.

After all of these different pieces of apparatus have been mounted on the baseboard and on the panel, you are ready to begin the wiring.

The first thing that you should wire in is the primary taps of the variocoupler. The variocoupler the Erla people show is made by the A. E. Hill Manufacturing Company, at Atlanta, Ga. This coupler is the "wide spread diamond wound" winding and comes equipped with empire cloth tubing on the leads. This makes a very desirable feature in mounting the variocoupler to the switch contacts, as they are so spaced on the variocoupler as to allow an easy and short lead from the primary to the switch contact.

In wiring up the primary, wire the taps which are the units or the single turn taps on the left hand side, on the left switch. Then the other taps of ten turns to a lap, go to the right hand switch lever. In doing this you will find that you can put the leads in absolutely straight line without having them crossing each other or being mixed up in any way.

After the switch contacts have been wired in, the next best thing to start on will be the wiring of the plate and grid leads of the tube sockets to the minus filament and plus filament posts on the radio frequency transformer sockets. These can be made very short if you have the baseboard laid out the way it is shown in our diagrams. These leads should not be over a half inch long, as the wires can be run direct from one binding post to the other.

After you have these binding posts wired in, the next thing to wire in would be the filaments of the tubes.

Run the two movable arm contacts of the rheostat together and also run

(Continued on Page 41)

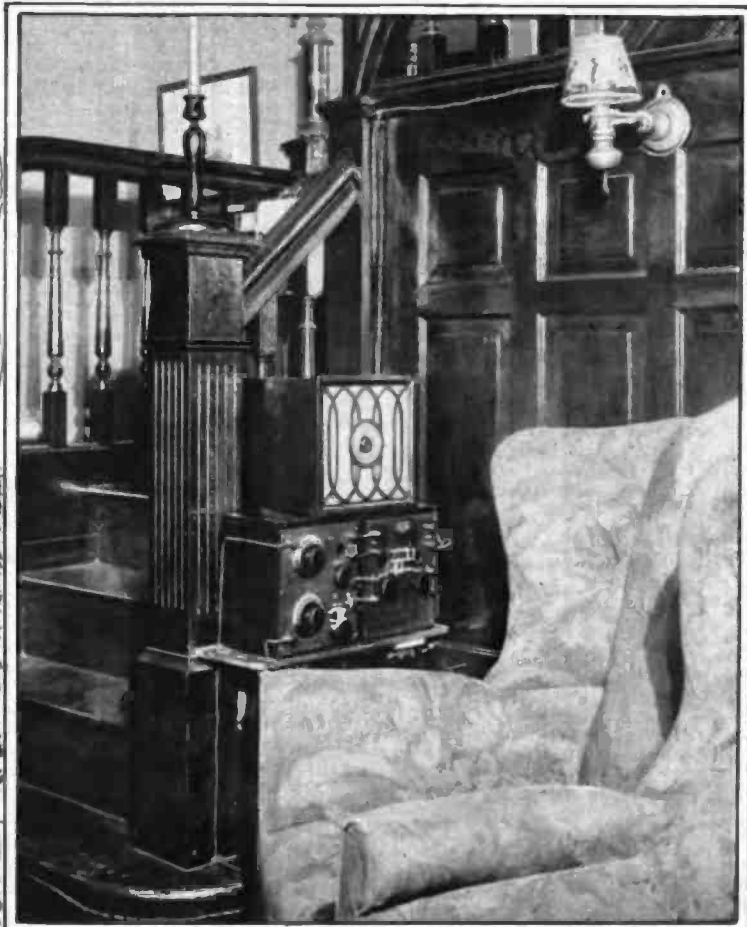

Radio in the home of Howard G. Ford, 5931 Webster St., Phila., Pa.
Photo courtesy of J. S. Timmons & Co.

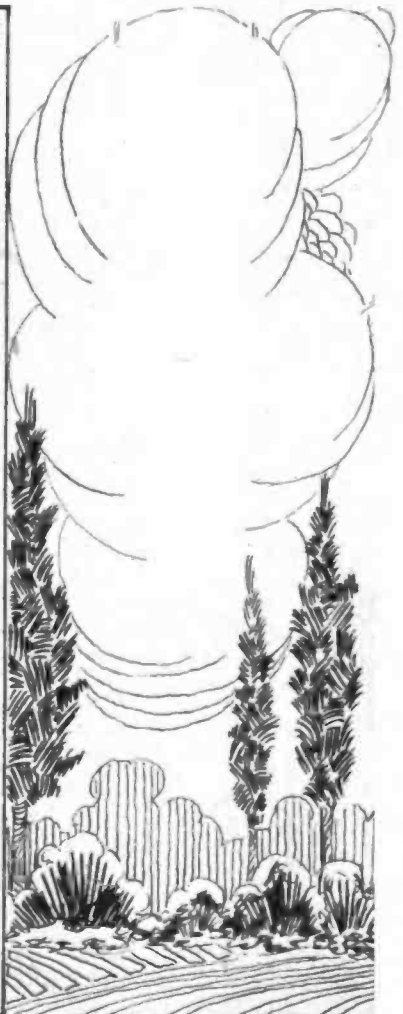



The Greatest Recent Contribution to Radio-

HAVING produced the finest of Radio Reproducers and audio-frequency Power Amplifiers in separate units, the next logical step on the part of Magnavox engineers was to combine them in one unit. Ask for Magnavox A1-R or A2-R, as illustrated.

Magnavox Reproducers	horn and 1 stage of amplification	
R2 with 18-inch curvex horn		\$60.00
R3 with 14-inch curvex horn		\$35.00
M1 with 14-inch curvex horn.		Requires no battery for the field
		\$35.00
Magnavox Power Amplifiers		
A1—new 1-stage		\$27.50
AC-2-C—2-stage		\$55.00
AC-3-C—3-stage		\$75.00

Magnavox Combination Sets
A1-R consisting of electro-dynamic Reproducer with 14-inch curvex

Magnavox Products are for sale at Registered Magnavox Dealers everywhere. Write for new 32-page Magnavox Radio Catalogue.

THE MAGNAVOX CO., Oakland, Calif.

New York Office: 370 Seventh Avenue
Perkins Electric Co., Ltd., Montreal, Canadian Distributors

MAGNAVOX

Radio

Reproducers and Amplifiers

WEAF

(Continued From Page 36)

WEAF, also many stars of the first magnitude in the theatrical and motion-picture world. Over 200 separate programs have been broadcast, involving a total of 3000 people, including artists. According to our best estimate, there are probably upward of three-quarters of a million radio receiving sets within the area easily reached by our station, and, as these sets will probably average not less than three listeners per set, we have a possible audience of between two and three million people.

"Practically the entire art of telephony has been created and developed during the forty-five years which have elapsed since the first commercial telephone exchange was established in New Haven, Conn., in January, 1878, and the remarkable progress which has been made is largely due to the results achieved through the co-operation of the associated companies of the Bell System under the general direction of the American Company in devising, investigating and putting into practical operation successive improvements which have resulted in the development of the telephone service in America to a far greater extent and higher point of efficiency than anywhere else in the world.

"New York City, with a million less population than London, has three times as many telephones and has substantially the same number as Great Britain, with a population of eight times that of New York. In South America there are four telephones per thousand population, in Europe twelve telephones per thousand population, and in the United States 125 telephones per thousand population, and, in total, two-thirds of the world's telephones are in the United States, the Bell System and connecting companies operating a total of approximately fifteen million telephone stations in the United States.

"From the foregoing you will appreciate that we are vitally interested in anything relating to the development of the art of communication and the transmission of the human voice. A great amount of the apparatus used in radio broadcasting is not new to us, much of it having been used for many years in our land lines telephone work and many of the principles which underlie radio transmission have been effectively applied in connection with the transmission of the human voice over wires.

"In the fall of 1915 we transmitted speech for the first time by radio from Arlington, Va., across the Atlantic to Paris, France, and across the American Continent to San Francisco and over the Pacific to the Hawaiian Islands.

"While our experiments and investigations clearly demonstrate that radio telephony cannot be effectively used where it is practicable to erect telephone wires, radio broadcasting opens up a new field of communication and our broadcasting station has been established in order to determine how broadcasting can be made a solid, permanent institution for good, developed to the highest degree of service to the public.

"We have asked you continually to write us regarding our broadcasting efforts and have received many valuable suggestions which have aided us materially. During the nine months we have been broadcasting you have written us over 25,000 letters and we have received as many as 1300 in a single day, to say nothing of the thou-

sands and thousands of telephone calls and telegrams.

"We are thoroughly alive to the deep interest taken by the public in radio broadcasting and we are leaving nothing undone to develop it to the highest possible extent.

"Behind the scenes of this station, serving you seven days a week, is a staff of over fifty people, experts in their various lines, and we know it is difficult to appreciate the refinements involved and the detail of operation required in order that WEAF may present to you a satisfactory and enjoyable program."

The most important feature of the new studios are the special arrangements designed to eliminate delays between numbers of the program and also the special methods introduced to make possible the perfect balance and placement of artists for the best radio reproduction. As a result, the music heard by means of good radio receiving sets is of excellent musical quality.

The delays in programs are eliminated by the use of two studios. While artists are preparing to broadcast in one studio, the other is "on the air," so that when a number is completed, the other studio is ready to be switched on instantly.

WEAF's soundproof announcer's booth gives clear vision to both studios. A loud speaker in the booth gives the announcer a reproduction of the performance in the studios as it is heard in the ether. Because of this arrangement, the announcer can place his artists about the microphone so that the best possible radio reproduction results.

Since the reassignment of wavelengths on May 15, WEAF has been transmitting on a wave length of 492 meters. Its present schedule is from 11:00 to 12:00 A. M. from Tuesday to Friday, inclusive; from 4:00 to 5:30 P. M. and 7:30 to 10:00 P. M. each weekday, and from 3:30 to 4:30 and 7:20 to 10:00 P. M. each Sunday.

The photograph at the top of page 8 shows most of the big staff connected with WEAF. Those in the picture are:

Left to right, lower row: B. Donnelly, E. R. Raguse, E. F. Grossman, E. J. Content, W. A. Irvin, G. E. Stewart, D. McKey, M. J. Woods, E. H. Felix, G. W. Johnstone, H. F. McKeon.

Second row, seated: R. H. Caldwell, H. Schoenberger, O. B. Hanson, E. R. Taylor, F. S. Spring, W. E. Harkness, G. F. McClelland, S. L. Ross, V. A. Randall, H. C. Smith, G. Chatfield, G. J. Podyen.

Third row, standing: A. V. Llufrío, M. Lamphere, N. A. Conner, A. Hunt, A. Cheuvreux, E. E. Sniffin, G. Weightman, A. Piana, H. F. Starrett, E. L. Schneeweiss, J. Land, H. Hann, W. F. Barr, G. Turner, E. Howland, A. F. Castleman, M. Jackson, E. M. Charles, W. Rickert, M. Adler.

Fourth row, standing (left): A. Ropps, G. McElrath, A. H. Saxton. (Right) J. J. Beloungy.

Away on duty: J. G. Truesdell, J. L. Reynolds, R. S. Fenimore, A. P. Protzman, M. Lorenzen, G. McNamee, A. I. Henley, W. Sweeney, E. R. Culen.

The executives of the departments are as follows: W. E. Harkness, manager of broadcasting; J. G. Truesdell, in charge of plant department; G. F. McClelland, in charge of commercial department; S. L. Ross, director of programs; F. S. Spring, office manager; V. A. Randall, studio director.

—Still Editorially Speaking

(Continued From Page 21)

Personally I do not think so. I do not think that class of people is worth considering very seriously if we are going to place radio upon the foundation which it deserves.

Let me give you just one instance to illustrate my point.

Last winter I put on at Station WIP, Gimbel Brothers, in Philadelphia, of which I am director, a series of Sunday afternoon classical orchestra recitals. This series of recitals was supervised with extreme care and was designed especially to appeal to the cultured and the more intelligent class of people.

During weekday evenings we put on frequent programs of the very popular, light, frivolous and jazz variety.

The response which we received in letters was very significant. The jazz musical programs always brought in great bundles of enthusiastic mail. The Sunday afternoon classical programs brought in an extremely moderate response.

We broadcast almost two seasons of Wagnerian opera from the Metropolitan Opera House and this series also was interesting in its results. The volume of mail was quite large, but it was about equally divided between those who approved of the opera and those who very grudgingly admitted that we probably had the right to put such things on, but that we ought not to do it very often; that jazz was the thing to make radio popular.

Since then I have found an interesting commentary upon all this.

In going about among the public, in lecturing as I have done a great deal and in speaking before luncheons and dinners, I have virtually, without exception, had people come up to me and speak of last year's broadcasting from WIP and always their enthusiasm was for the Sunday afternoon classical concerts.

Why was this?

Without meaning to flatter myself in any way I will simply point out the fact that my own friends and the people whom I ordinarily meet, the people who belong to these better class luncheon clubs and who give the better grade of banquets, are the intelligent and educated and cultured class of people.

I took particular pains to talk to all whom I possibly could to find out whether they had ever written to the station to tell us how much they enjoyed these concerts. I think, if my memory serves me right, that, out of all of the hundreds of talks, I discovered just three who had written letters about the concerts.

All of the others said that they had intended to write but that something interfered, or else—which seemed to be the favorite excuse—they thought that we were so overwhelmed with letters at the station that it was better not to write at all.

This has confirmed me in my opinion that the people who are worth while for radio are not the class of people who write letters to broadcasting stations.

Following this, then, in its logical sequence, you will see how I arrive at my conclusion that any analysis of the broadcasting public founded upon the letters received at a station is an analysis which will totally ignore the very class of people upon whom we must depend if radio is to reach the stage of dignity and usefulness already reached by the piano, the automobile and the Victrola.

Any policy of operation of a broadcasting station founded upon these letters will be a policy which will please the great mass of people who

make their own sets out of cardboard boxes and wire secured by unwinding spark coils.

But it will entirely alienate the best class of people without whom we can never go forward to the position which we should obtain in the world.

You may think from this that I am unduly prejudiced against people who are not endowed with this world's goods. I am not. I have lived a great part of my own life among them and have been a member of that same class myself.

I am forced to admit, though, that they are not the kind of people who are going to "make" radio. This is to a very large extent due to the fact that my position as a director of a broadcasting station has shown me that radio broadcasting requires a great deal of money if it is to be properly done.

More and more broadcasting stations have come to realize that their greatest attraction is in what we call "remote control stations." This means that the actual singing or playing or speaking takes place at some point remote from the studio itself and must be sent first over land wires before it is transmitted from the radio aerial.

I wonder how many of my readers realize the tremendous cost of a chain of remote control stations.

At the present time, such a station costs something in excess of \$2000 for installation and about \$600 a year for carrying charges, to say nothing whatever about salaries and expenses connected with actual operation.

We at WIP have eight of these

remote control stations. Figure this up for yourself and you will realize just one item of the tremendous expense of such a station as is being maintained by Gimbel Brothers in Philadelphia alone.

Every now and then each large station in a city will do some special "stunt," such as broadcasting from the ringside of a great fight or the complete play-by-play description of the World Series baseball games.

Have you any idea what it would cost us at WIP to broadcast the World Series games from New York this past month?

As a special price to us, we were quoted \$500 per game for the first five games and \$400 per game after that.

Can you tell me where a department store is going to get such money as this back again?

If Gimbel Brothers were to spend that amount of money in newspaper advertising of a shoe sale or a furniture sale they could, within forty-eight hours, put their fingers upon every cent of that money brought back to them again, and every cent would have brought perhaps another cent of actual financial profit to them.

But how can they place their fingers upon the financial profit of broadcasting such an event as the World Series baseball games, which, even with the ordinary news ticker service, would be known to the public within fifteen minutes after the actual play took place?

Such charges as this—even assuming that they are really necessary—are shortening the future of radio broadcasting as it is today, and the solution of the problem of who is to pay for this broadcasting and who is going to have brains enough to reduce the excessive charges for

(Continued on Page 45)



Beauty, convenience, reliability—these you have in the Durham de Luxe Tea Wagon. The Mu-Rad receiver has an established record for distance without any separate wiring. Yet, with all accessories, it is entirely concealed in this exquisite piece of furniture. Thoroughly practical as an entertainer—for tea, for radio, or both—this is the set for homes of distinction.

DURHAM & COMPANY, INC.
1936 Market St. Phila.

The "A" Battery's Power in Your Radio Receiving Set

THIS IS NUMBER TWO OF A SERIES

THE sole purpose of the "A" Battery in your Radio Receiving Set is to furnish current to heat the filaments of the tubes.

And this can be done satisfactorily only by an "A" Battery that supplies an adequate steady current.

Anticipating the popularity of the dry cell tube in Radio, and realizing that it required a Dry Cell capable of standing up under service conditions differing from what dry cells are called upon to meet in other fields, the National Carbon Company developed the Eveready Radio Dry Cell specifically for this new use.

A dry cell gives its maximum service only when designed especially for the work it is intended to perform. There are for dry cells several uses which are so alike that one type of cell serves for all. This is the field covered by the ignition or general purpose dry cell.

The conditions encountered in Radio are different from the conditions grouped together under the term "general purpose." And while the general purpose dry cell performs well as an "A" Battery, it was found possible to produce a Dry Cell "A" Battery capable of delivering more service on Radio loads.

Thirty years of dry cell experience and an immense research organization resulted in the superior Eveready Radio Dry Cell. One of the outstanding features of this special cell is that while it will last much longer when used as an "A" Battery, it is no larger than the standard dry cell.

The increased service life of the Eveready Dry Cell "A" Battery greatly offsets the slight increase in cost; so this battery is not only the best, but it is the most economical you can buy. "The Story of Eveready Dry Cell Radio 'A' Batteries," which tells how to use Dry Cells to the greatest advantage with the various dry cell tubes now available, will be sent to you free on request.

The "A" Battery gives power to your Radio Receiving Set. Eveready Batteries—especially made for Radio—serve better, last longer, give better results.

Note: This is number 2 of a series of informative advertisements which will appear in this magazine. They are designed to help users get the most out of their Batteries and their Radio Sets. If you have any battery problem, write to G. C. Furness, Manager Radio Division, National Carbon Co., Inc., 120 Thompson Ave., Long Island City, N. Y.



POWER

for Your Radio Set

Eveready Dry Cell Radio "A" Battery
(No. 7111)

Directions and wiring diagrams on the jacket tell just how to use this battery with the different dry cell tubes.

This special Radio Cell is also available in two and four cell multiple batteries for receiving sets employing from two to four WD-11 or WD-12 tubes.

Other Radio Batteries

Eveready Storage "A" Batteries—best suited for filament heating of all Radio Tubes not especially designed for dry cells. The quality storage battery with the long life plates, \$15 to \$20.

Eveready "B" Batteries—the life of your Radio.

Eveready "Three" Battery—3 cells, 3 purposes.

Manufactured and guaranteed by

NATIONAL CARBON COMPANY, Inc.

EVEREADY

Radio Batteries

—they last longer

A New Idea in Crystal Sets

(Continued From Page 35)

long distance with a number of different crystal sets.

Late in the summer just past, with this set, I began to pick up long distance almost every evening.

Three miles from the center of Philadelphia, where the broadcasting stations are situated, I get them all and separate them all and also tune in stations as far away as Troy and Schenectady, New York.

Just before writing this article I listened in on the market reports from KDKA, Pittsburgh.

But do not try to get long distance unless your aerial is already giving you local reception strong and loud.

Some additional equipment is desirable, although not absolutely necessary.

You should have a test buzzer. This will insure your having your cat-whisker in proper contact with the crystal. Closing the buzzer circuit for a few seconds and moving the cat-whisker a few times, you will find the buzzer note louder and stronger than before. When going after long distance, this buzzer test should be repeated from time to time, and when long distance is obtained and fades away—a touch on the buzzer button will often bring it in strong again.

If the buzzer note is strong and the long distance does not respond again promptly after fading, do not move your sliders, but wait. It will come back with renewed strength in a little while.

The other desirable piece of equipment is a variable condenser—forty-three plate, if possible. This is connected to the binding post at the base of the cat-whisker and to the phone post nearest you, as you face the set.

Set the plates of the condenser at about half mesh and then tune in

with water and allowed to dry will be all the cleansing it requires.

But the cat-whisker. Take it out of the holder by main strength. File the tip sharp. Do this fifty times to cleaning the crystal once. Squeeze the supports together a little before replacing. You should learn to adjust the cat-whisker so that you receive maximum signals and yet not disturb it when you pound on the table with your fist. You should be able at all times to put additional phone connections on the phone springs without disturbing your crystal contact. And, of course, at all

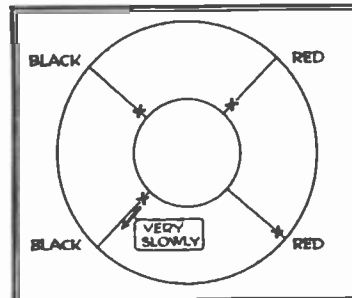

This is the method of tuning the coil from the center.

times you should operate the sliders without disturbing the crystal.

The novice will find this set simple and easy to master.

The expert will delight in the unlimited range of combinations he can try out. As an experimental test set it would be a valuable addition to every research laboratory.

Mr. Neely, editor of *Radio in the Home*, after a trial, tells me this is the best crystal set he has ever seen.

He asked me to write an article telling you how to use this set to best advantage.

For two months, since perfecting this device, I have listened in every evening from two to four hours. I have tried and retried, tested and retested, every way of operating or hooking up I can imagine and I cannot tell you the best way. I can only tell you as above—the best ways I have found.

During the next few months, as one subscriber to *Radio in the Home* after another tries out this set, there will be a steady stream of letters to Mr. Neely telling him of still newer ways of operating it. The range of combinations is as unlimited as those of a three-dial set. They run into the thousands. I have only tried out a few score and—as I have just thought of another, and want to try it out on that Schenectady concert this evening—this will be about all I have to say now about the set.

Still Editorially Speaking

(Continued From Page 39)

it, is vastly more important than these abortive attempts to solve the riddle of the public's wants by means of letters which come from only a small class of the public, and not the class, at that, which are really paying for our hobby.

The public taste can easily take care of itself. It has been taken care of by editors with their newspapers and by great magnates with their theatres and by great men in other lines of effort who know what the public wants.

The problem to be solved now—and one in which analysis and investigation are very pertinent—is how are we going to reduce this cost, and, even when we have it reduced to less than half of what it is at present, who is going to pay for it?

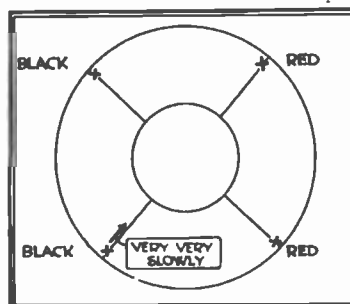

This is the method of tuning the coil from the outer side.

until some station is received at maximum strength.

Then by turning the condenser dial to right or left you will tune to greater or lesser wave lengths and if set correctly this tuning will be very sharp. I have succeeded in this way in listening in to Schenectady on 380 meters 200 miles distant, while WDAR or WFI at 395 meters were going at full strength only three miles away.

While writing this the announcement from Station WIP comes to me across the room through the clatter of my none too quiet typewriter.

You may find the above method of operating brings best results by tuning from the outside, but length of aerial and other outside conditions may modify this considerably.

Crystals should never be cleaned unless your set is so close to the stove that grease from the frying pan bespatters it. A little ammonia or wet table salt put on without rubbing for a few minutes and then washed off



Superior
**QUALITY
WORKMANSHIP
PERFORMANCE**

Make
**LANGBEIN & KAUFMAN
VARIOMETERS and
VARIOCOUPERS
THE BEST**

*Highly polished PURE
HARD RUBBER
forms, double silk covered
wire, highly nicked brass
hardware — all skillfully
assembled*

L. & K. wire-wound instruments are to be had in seven different windings, an instrument for every use.

Standard Variometer...\$7
Standard Variocoupler...\$7

NEW!!!

**A UNIVERSAL
VARIOMETER**

A split variometer applicable in 101 ways. An instrument for the experimenter as well as the set builder.

Send for Literature

LANGBEIN & KAUFMAN
654 Grand Avenue
NEW HAVEN : CONN.



**Erla Three-Tube
Reflex Circuit**

(Continued From Page 37)

them to one side of the A battery switch which cuts out the filament battery from the tubes. Then run all of the plus filament leads together and run them directly to the first binding post next to the panel on the right hand side—this is the plus A battery binding post.

Then the next binding post to that is the minus A or minus filament binding post and should go directly to the A battery switch. Then the other connections from the rheostat should go to the minus filament binding post on the tubes—that is, run the first two tube socket negative binding posts together and from that run the wire to the binding post on the rheostat. Then the third tube socket should have the minus filament run to the connection on the rheostat.

Then run a wire from the minus B battery post to the minus A battery post. Then the last binding post is the plus B battery and should run up to the two outside terminals on the jacks, and also to the grid binding post of the first radio frequency reflex transformer. In this circuit we do not have a 22½ volt B battery binding post or a connection of the 22½ volt B battery, as this circuit uses the crystal and we do not use a soft tube, but instead we use three hard tubes with about 100 to 135 volts on the plates.

The next best thing then to wire in on this circuit will be the two variable condensers. By looking at the wiring diagram you can very easily see where these connections go. After these variable condensers have been wired, wire in the crystal detector.

This only leaves us to be wired the rotor of the variocoupler and the audio frequency transformers.

There is a binding post on the side of the variocoupler which comes from the rotor.

This binding post should run to the grid of the first tube socket. The other connection of the variocoupler is made from one of the supporting legs and should be run to the negative filament lead.

This brings us down to the wiring of the audio frequency transformers and the wiring is the same as the wiring of any two-stage amplifier.

One connection from the crystal detector goes to the plate binding post of the primary of the first audio frequency transformer. The plus B battery binding post of that transformer goes to the plus filament post of the second radio frequency reflex transformer. In the secondary windings of this audio frequency transformer, the grid post goes to the plus post of the first radio frequency reflex transformer and then the minus filament post of the first audio frequency transformer goes to the minus filament.

The other audio frequency transformer in the primary goes to the inside blades of the double circuit jack.

Of the outside blades, one has been connected to the plus B battery and the other goes to the grid post of the second radio frequency reflex transformer socket. In the secondary of the second audio frequency transformer, the grid post goes to the grid binding post of the third tube socket and the filament binding post goes to the minus filament.

Now say we have the whole circuit wired and we are ready to insert the radio frequency reflex transformers.

You will find on the bottom of these transformers the markings "Erla reflex number one" and "Erla reflex number two." Number two goes in the first radio frequency transformer socket and one goes in the second transformer socket. The windings of these radio frequency reflex transformers are of such a nature that

(Continued on Page 45)



ACTUAL SIZE OF INSTRUMENT

**How Many Miles Did You
Get on Your Radio
Set Last Night?**

When you tuned in that out-of-town station last night and the tones came over clear and resonant, did you know the exact airline mileage your set received?

McNeary's Scalometer, Official Radio Map and Broadcasting Directory answer this question instantaneously. It's

simple! Place the Scalometer at your home station (keep it mounted there always), extend the tape to the station received—and there before your eyes, in clear, legible type, you've got your answer.

McNeary's Scalometer is a wonderful joy-producing device and should be in the home of every radio owner.

**McNEARY RADIO
SCALOMETER**

together with RADIO MAP and BROADCASTING DIRECTORY **\$1.00**
See this SCALOMETER at any radio shop **1** Complete

If Your Dealer Cannot Supply You, Send One Dollar to

EMBLEM MANUFACTURING CORP.
261 Middle City Bldg., Philadelphia, Pa.

GAMBLING?

You Are If Your Radio Tubes Are Unprotected



Your Vacuum Tubes are the most delicate parts of your Radio Set. They are easily blown out—you have probably already had this exasperating experience—it is apt to happen at any time.

"B" Battery wires accidentally crossed for only an instant with the filament leads or sudden excess current from the "A" Battery will do it. You can prevent this and save yourself money and inconvenience and relieve your mind at a trifling cost.

INSTALL

RADECO SAFETY FUSES on all your tubes. Applied in an instant to one of the filament terminals. Will fit any standard tube going in any standard socket.

Price 50 cents each, sent postpaid and fully guaranteed. Do not delay. Order now. Specify type of tube used.

DEPT. 11

RADIO EQUIPMENT COMPANY
Manufacturers and Distributors of Standard Radio Equipment

630 Washington Street, Boston, Mass.
New England's Oldest Exclusive Radio House
Dealers—Write for our proposition.

**RADIO
IN THE HOME**

is devoted entirely to better class radio—the only kind that is fit to go into the American home.

RADIO IN THE HOME

is not in the market for general radio advertising. We make our own tests of apparatus and our own investigations of the financial and commercial reliability of firms, and we solicit advertising only from those manufacturers whose products we ourselves are willing to guarantee in the light of these researches.

This is to assure our readers that they can depend on the things they see advertised in our columns.

It is a Reader Service



WRITE FOR BOOKLET
AND NAME OF
THE NEAREST
MU-RAD DEALER:

No Extra
Battery
Connections.
PRICE

\$25

MU-RAD LABORATORIES, INC.
798 FIFTH AVE. ASBURY PARK, NEW JERSEY

Memo Pad

What I will need to make a good tube set

- A Kellogg No. 501 variocoupler
- A Kellogg No. 605 variable condenser
- A Kellogg No. 2 tube socket
- A Kellogg No. 505 miniature condenser
- A Kellogg No. 503 mounting
- A Kellogg No. 501 jack and plug
- A Kellogg No. 502 dial
- A Kellogg No. 69A head set
- A Kellogg No. 501 rheostat
- A Kellogg switch and switch points
- A and B batteries and cabinet
- A Detector tube

Kellogg radio equipment is recommended for several reasons

First — It is easy to install and simple to operate.

Second — It is built of the highest grade material to give the best possible results.

Third — It is electrically and mechanically correct and will last a life time.

Fourth — It is built by the Kellogg Switchboard and Supply Co., who have manufactured high grade telephone equipment for the past 25 years.

Fifth — Every Kellogg radio part is GUARANTEED by the manufacturer.

"Use, is the test."

Get the above apparatus at your dealer.

KELLOGG SWITCHBOARD & SUPPLY COMPANY
1066 W. ADAMS STREET
CHICAGO, ILLINOIS

The Radio Kindergarten

(Continued From Page 17)

know that it is made to do this by the magnetism that is everywhere around the earth's surface. But we also know that if we cause an artificial whirl of magnetism near the compass stronger than the earth's magnetism this artificial whirl of magnetism will affect the compass needle, and will show its effect by deflecting the needle.

Now let us leave our instruments hooked up as they were, but lay this little compass under the wire in the first circuit so that the wire will rest upon the glass case.

Now let us close the switch in the first circuit and start the current of electricity flowing from the battery.

Immediately the needle of the measuring instrument flies to one side and the needle of the compass also flies to one side. But, whereas the needle of the measuring needle immediately flies back to zero, the needle of the compass stays there at the point to which it has flown.

The compass thus proves that the current of electricity continues flowing in the first circuit, but the indicating instrument in the second circuit shows that the only current caused there is caused when the magnetism is in actual motion.

Now, it is very simple to reason out for ourselves just why the making and breaking of the first circuit will create first a positive and then a negative current in the second circuit.

When we make the current in the first circuit flow, it throws out the magnetism very suddenly, and this magnetism, being in rapid action, cuts through the second wire and causes just a momentary impulse of electricity. As soon as the magnetism is thrown out by the first circuit, however, it stays exactly where it is, or, in other words, it is at rest.

Then when we open the switch and stop the flow of electricity in the first circuit, this field of magnetism collapses and falls back upon the first wire. Here again we have magnetism in action cutting through the second wire, but it is cutting through in the opposite direction, and so causes an opposite current in our second wire, just for a momentary impulse.

That proves that there was an entire reverse of current in the second circuit which contains the measuring instrument. In other words, if the first flow of current caused the needle to fly over to the left, the current must have turned around and gone in the other direction to cause the needle to fly over to the right. If the current had simply died down, instead of reversing, it would merely have come back to zero.

We can learn several things from these experiments that we have performed.

The first is that a direct current induces a temporary current in the second wire, but this current immediately dies down.

Second, we learn that an interrupted direct current, which we get by closing and opening the switch in the first circuit, will cause a true alternating current in the second circuit or a current which is first positive and then negative.

This latter fact is very important to bear in mind. Many writers of radio articles will tell you that an interrupted direct current will simply cause or induce an interrupted direct current in the second circuit, but this is not so. The current that is induced in the second circuit by interrupted direct current in the first circuit becomes a true alternating current and

reverses its direction with the making and breaking of the first current.

This is very important to remember, because it is exactly what we do in our transformers. We send an interrupted direct current from the B batteries to the plate of the tube through the first winding of the transformer, and this interrupted direct current causes an alternating current in the secondary winding of the transformers, and this alternating current is fed to the grid of the next tube and operates it in the way required for radio reception. If it were not a true alternating current, the tube would not function properly.

Perhaps even this is not intelligible to some of you because you may not know just what a transformer is.

We can easily explain it by doing a very simple thing with the apparatus which we already have on the teacher's desk, so let us go now and do it.

The way we have had the apparatus hooked up, we have had one wire of the primary circuit lying very close to and alongside of the one wire of the secondary circuit. Now let us do this in a little different way.

Let us take the secondary wire and wind it ten times around a lead pencil, and now let us take the primary wire and wind that ten times over the top of the secondary coil which we have just put on.

When we close the switch now we see that we have again created a current of electricity in the secondary circuit, but the needle of the measuring instrument will fly over a great many times farther from the zero mark than it did before.

This shows us that winding this wire into a coil has in some way increased the amount of current which we have been able to produce or induce in the secondary circuit.

I do not think that this is very difficult to understand if you will reason it out in this way:

If the electricity in the primary will induce a current in the secondary wire, it is perfectly natural to suppose that when we wind the primary in a coil, the current in the first turn of the coil will induce some energy in the second turn of the coil and that this induced energy in the second turn will be added to the current which the battery is sending out.

Then the stronger current in the second turn will send out magnetism and induce a still stronger current in the third turn, and that again will add to the battery current, and so we keep on building up the strength of this current from turn to turn when we wind our wires in a coil of this kind.

Now let us unwind these coils and put them on in a different way. Instead of putting on ten turns of the secondary wire we will wind on twenty turns. Now let us take the primary circuit and again wind on ten turns as we did before.

We now have twenty turns on the secondary and ten turns on the primary.

Let us close our switch. Immediately we see that the needle on the measuring instrument flies over a great deal farther than it did in the previous experiment.

We have simply made a transformer. We have made what we call a "two to one" transformer because we have twice as many turns of wire in the secondary as we have in the primary. Before this we had a "one to one" transformer because we had the same number of turns in

(Continued on Page 44)

See the world and be paid for it!

The Philadelphia School of Wireless Telegraphy has graduated hundreds of men who are seeing the world as Radio operators and these men are earning good salaries aboard some of the largest ships.

Our courses are thorough and practical — and are taught you in the shortest time possible.

Positions secured
for our graduates

DAY AND EVENING COURSES

"Send today for Illustrated
Booklet"

**Philadelphia School of
Wireless Telegraphy**
1533 Pine Street
Philadelphia

Radio Now Billion Dollar Business

(Continued From Page 31)

Just a little interesting incident in this connection is that the speaker was the one to get the first pictures before this station was officially opened on the third of July, 1923.

Some day perhaps there will be other stations connected by wire which can get the benefit of these wonderful programs. Would this interest you?

The next important element in the broadcasting field is the great organization known as The General Electric Company with their home office at Schenectady, N. Y. They told us they are erecting another station at San Francisco, which will soon be ready.

I cannot take time, as I would like to do, to have you meet the splendid men connected with this great and capable organization—but some time later perhaps.

Now we must go on to get acquainted with another very big house in this big industry—the Westinghouse Electric and Manufacturing Company, with their home office in East Pittsburgh, Pa., where is located Station KDKA, with two other very capable stations at Springfield, Mass., and Chicago, Ill.

Now the fourth element in this headliner broadcasting is the Radio Corporation of America, with two stations in New York City and one in Washington, D. C., of which latter station the speaker also had the privilege of getting the first photographs, not only of the station, but of the personnel as well. We must pass briefly over this, as well as some of the other big stations, but hope that at some future time we will have opportunity to treat them more fully.

At Medford Hillside, Mass., is the station of the American Radio and Research Corporation.

On the top of the 1100-room Hotel Statler in Buffalo is the very fine station of the Federal Telephone and Telegraph Company.

In Cleveland on the top floor of one of the most beautiful buildings in America, which is owned by the Union Trust Company of Cleveland, with its \$300,000,000 resources, is another very fine station.

The Detroit News, of Detroit, in its new building of beautiful architecture, has a station which is both large and exceedingly well managed, and a station also in which the men are full of great hopes and plans for the benefit of "listeners-in."

If you could only visit that exquisite Palm Room lobby of the Drake Hotel in Chicago, and its broadcasting station, if you could only look up and down the shores of Lake Michigan from the exquisitely designed Edgewater Beach Hotel in Chicago; if you could only visit with me St. Louis, Cincinnati, Denver and Kansas City; if you could have attended in Toronto the assemblage of that chorus of 2300 voices, then you could perhaps get some idea of the expenditure of thought and money to give pleasure to you and me.

There are 3,000,000 sets now owned in America which leaves close to 20,000,000 sets yet to be sold.

We all know that just the lure of distance is not all we want; we want quality. In the very near future, although we have been receiving wonderful concerts, the programs will be still more wonderful.

In the beginning of this talk, I briefly summed up how I got into the radio game, but I was not specific. The man who is mainly responsible for me is your own dear friend, "Dream Daddy," Mr. Harry Erhart, who enthralled me with his voice and smile, the same as he has done to many other unsophisticated children

and parents. And through him I met Henry M. Neely. And because Mr. Neely wanted to be right before he went ahead this investigation of mine has been made.

Some day perhaps you can visit with me, in addition to the men I have mentioned, others connected with the American Telephone and Telegraph Company: Mr. Harkness, that pleasant personality around whom is written Capability, who is in charge of broadcasting; Mr. Ellsworth, in charge of publicity, whose dignified personality spells reliability; Mr. McClellan, an exceedingly live wire, and Mr. Felix, assistant in charge of publicity.

In the General Electric Company I would like you to shake hands with Mr. Swope, the president; Messrs. Gale, Rice, Davis and Lange, in charge of various important departments.

In the Westinghouse crowd I would like you to meet at least Mr. Conrad, the fundamental reason for this great company going into broadcasting; also Mr. Brackett and Mr. Chubb, Mr. McQuiston, Mr. Rogers and magnetic Mr. Davis, vice president, who has been the broadcasting inspiration.

In the Radio Corporation of America you would get an entirely different viewpoint on radio if you could meet Mr. Young, General Harbord, Mr. Sarnoff and Mr. Bucher.

And then, while not so popular, there are two or three other very vital and interesting figures in the radio field at the present time. Two of these are Philadelphia men each approaching the radio situation from a different angle. Mr. A. U. Howard, who resides in Chestnut Hill, is vice president of the Dubilier Condenser and Radio Corporation, and he has given the writer a total of fifteen hours to discuss radio from the public angle.

Mr. Walter Eckart, of the General Radio Corporation, approaches radio from the music and beauty side.

Mr. Furness, of the National Carbon, is telling his story in color, during the next few months, in one of our national periodicals.

Thus we have the big element in radio, men, creative geniuses.

Radio has its Horace Farnum Griffiths, of the movie world; its Washingtons, Jeffersons, Lincolns, of the political world; its Benjamin Franklins, Henry Ward Beechers, of the literary world; its Edisons, Fords and Steinmetzs, of engineering and business fame, and in the very near future it will have the same worldwide notable characters among women because it is going to be women's duty to direct the broadcasting industry by their suggestions, which suggestions must be the result of their own wonderful intuition and carefully prepared analysis. It is with this object in view that *Radio in the Home* is carrying the word to thousands of women's clubs by talks throughout the United States.

The next side of our investigations has been the apparatus side. Just considering the seventy-five rated concerns, to compile their histories, their financial standing, to visit them, to study their personnel, to get their viewpoint on the past, the present and the future, to test their products, has been, as far as we are concerned, a great task of itself—far too great to go into at the present time. To divide this off into sets, parts, accessories, amplifiers, phones, batteries, etc., is really a greater task than many could conceive.

Home is the most beautiful word in the world, the word around which books and poems have been written

(Continued on Page 46)

INSTRUMENT
DEPENDABLE

MAKERS

SINCE

PRODUCTS
1900

PRECISION HIGH EFFICIENCY CRYSTAL SETS

Guaranteed to receive local broadcasts with volume and clarity equal to any sets manufactured.



FREE

FAMOUS TESCO RADIO Crystal Set (Shown in Cut)

To introduce the wonderful T-B-H radio headset we will give absolutely free of charge, the most efficient crystal receiver on the market.

SEND NO MONEY

Just pay postman \$5.00 plus postage. Money refunded if not absolutely satisfied.

THE EASTERN SPECIALTY CO.
3552 N. Fifth Street
PHILADELPHIA, PA.

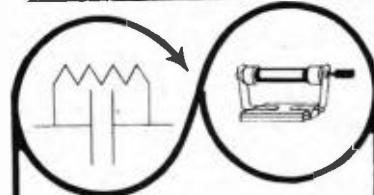

How to use grid leaks

A simple explanation of these important units is now ready for distribution. Copies will be mailed FREE to all present or prospective users of

DURHAM
With Variables
DUBILIER
Micadon

Resistance values in 3 sizes, variable from 1000 ohms to 10 megohms. Condensers in 2 sizes, .0005 mfd. and .0002 mfd. A combination for every tube, \$1.10 complete.

Booklet A, tells how to make your tubes do their best. Get a request for your copy in the next mail.

Satisfaction Guaranteed
DURHAM & CO.
1936 Market St., Philadelphia

DEALERS

Thousands of letters show that the public wants to know "how it works." DURHAM-DUBILIER dealers tell them with Booklet A—the first of its kind that we know of. Arrange for your supply.

TUNE HIM OUT!

Doesn't matter how near he is—or how strong.

If you don't want him, but DO want that distant, fainter station—TUNE HIM OUT.

Just a touch—and it's done.

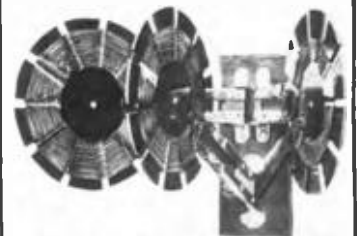

Goodman Coils, in their beautiful mount, are an ornament to any panel. Their sharp tuning is a joy to any radio fan. They can be used in any of the standard hook-ups, and improve them all. Diagrams given in our pamphlet. Send for one.

The FANS and PANEL are GENUINE BAKELITE. The tuner is well and sturdily made in every respect and is a real high-grade instrument. Awarded certificates of merit.

The finest short-wave tuner on the market

\$6.00 and P. P. on one pound

L. W. GOODMAN
Manufacturer
Drexel Hill, Pa.

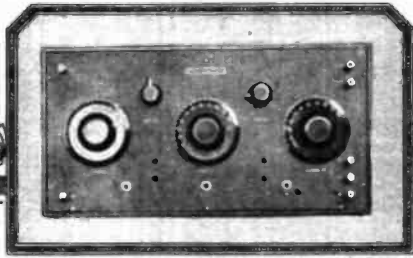

WITH THE ORDINARY SET

☞ You have to hunt for stations. ☞ You cannot tell where you will find them. ☞ You get howls and squeals. ☞ "Hand capacity" bothers you. ☞ You cannot "log" a station and be sure of getting it at exactly the same settings next week or next month. ☞ You must study your set carefully before you can handle it.

but—

NOT WITH A GAROD NEUTRODYNE A CHILD CAN OPERATE A GAROD

It Cannot Howl and Every Station Comes in
No "Hand Capacity" According to "Log"

The GAROD CORPORATION

120 PACIFIC STREET NEWARK, N. J.

- it must
be good—
Neely says
SO

The
**Death Valley
CRYSTAL, 30¢**

SINCE Henry M. Neely's article recommending Death Valley Crystal appeared in the July issue of "Radio in the Home" we have been flooded with inquiries as to where these crystals may be purchased. If your dealer has not yet stocked Death Valley, send 30c (cash or money order) and we will gladly fill your orders.

Death Valley features:

1. Entire surface is sensitive.
2. Natural mineral—not synthetic.
3. Cannot be damaged by handling.
4. Loudness and clearness cannot be equaled.
5. Will stand high-plate voltage.
6. Recommended by radio experts for reflex circuits.
7. Unless you use a "Death Valley" Crystal you have not developed the maximum efficiency of your set.
8. Sold only in sealed packages.

**30¢
Everywhere**

PACIFIC RADIO SPEC. CO.
Dept III 17 So. ORIANNA St. Phila.

The Radio Kindergarten

(Continued From Page 42)

the primary as we had in the secondary.

We can see from this that when you have several times as many turns of wire in the secondary as you have in the primary, you keep building up the strength of the current, or voltage, induced in the secondary. We can make a three to one or a four to one or a five to one or a ten to one ratio transformer.

Perhaps you may ask, then, why not make a transformer which will boost the current a thousand times in one transformer and so make it unnecessary to have all of the transformers we have to use in radio?

I am afraid that the class has not yet reached the point where I can easily explain this to it so that it can understand it, but you will simply have to take my word that there are limits to this ratio beyond which the process does not function efficiently. This limit is just about reached in a ten to one ratio transformer, and, in fact, even with that it is likely to produce signals in our head telephones or loud speakers which are badly distorted and not at all the kind of signals which we want.

So we find it much better to use a lower ratio of transformer and use more transformers with a bulb in between each two of them.

Some of the children in this class may think that I have gotten them into rather involved technical aspects in this lesson, but I want to plant this idea of induction very firmly in your mind, and now I will tell you why it is that radio is absolutely founded upon this phenomenon we know as induction.

When a signal is sent out from a transmitting station it is sent into the aerial as a very rapidly vibrating alternating current. This current hurls out magnetic impulses which alternate the same as the current of electricity in the aerial alternates, and these alternations, taking the form of magnetic waves or pulsations in the ether, are sent out in all directions.

Over at our house we have our own receiving aerial high up in the air. These magnetic waves cut through or across the wires of our aerial.

Now what have we just learned about the results of a magnetic impulse or whirl or wave or pulsation—call it whatever you will—when it cuts through another wire?

We have learned that it creates a current of electricity in that wire, haven't we?

Very well. The pulsations of magnetism caused by the electricity in the transmitting aerial, cut through our own aerial wires and create currents of electricity in those aerial wires and these currents we lead down from our aerials into our receiving sets and they are the impulses which are translated through all of the apparatus in our set into the sounds which we hear in our ears.

So you see that the very fundamental thing about radio—its ability to transmit sounds from one place to another in spite of the fact that the two places are not connected by wire—this fundamental phenomenon is caused entirely by induction, and that is why I say that it is necessary to get a mental picture of what induction is and what it does in order to see the fundamental basis upon which radio is founded.



High School

Radio Clubs

The Radio Clubs of the New York and Philadelphia boys' high schools have started a movement for a

National Organization

This movement will have many advantages to all members if we can organize chapters in the High Schools of all cities and suburban towns.

There will be co-operation and the financial advantages of co-operative buying, which means a saving on every purchase.

There will be stimulating contests for fine prizes.

There will be a free exchange of new ideas in hook-ups and radio "dope."

There will be an authoritative Information Bureau where our problems can be solved for you.

LET'S GET TOGETHER

The undersigned has been asked to get in touch with professors and radio fans in all boys' High Schools.

Please send me full information about your school—the number of pupils, whether you have a Radio Club, whether you think one could be formed and whether the faculty will co-operate.

In return, I will tell you just what has been accomplished in the growth of this big movement.

Address:

Executive Secretary
608 Chestnut Street
Philadelphia, Pa.

The Little Wonder of Radio—The "N" Tube

(Continued From Page 19)

denser. The grid of this tube socket runs to the well-known Durham-Dubilier variable grid leak and condenser. This in turn runs to the rotor of the variocoupler.

Looking at the front of the panel we see in the upper left-hand corner and the lower left-hand corner two binding posts. These are for the antenna and ground connections and then next to these on the right we have the dial which is fastened on to the rotor of the variocoupler. The next dial is the variometer and between these two at the top we have a series of switches and a switch lever. These are the primary taps of the variocoupler and below this we have the filament control for the tube. With this tube I would not advise you to use a wire wound rheostat.

We have here shown the new type Bradleystat and we find that we can get wonderful filament control with this.

Then in the right hand we have the variable condenser and in the extreme right-hand corner at the top and at the bottom we have two other binding posts. These are the binding posts for the telephone connections.

Now looking at the rear of the panel you will find we do not use a base board. Everything is self supporting on the panel—even the binding posts which are for the filament battery and the B battery.

The new little "N" tube is mounted in a very unique way. I happened to have a small piece of angle which I fastened on to the composition back of the variable condenser with a machine screw and then on the other side of this angle I fastened a piece of hard rubber with two machine screws, and mounted the socket on it.

The connections in this circuit are as follows: one connection from the antenna binding post runs to the switch arm and the switch arm makes its contacts through the contact points to the primary of the variocoupler. The end winding of the variocoupler goes to the ground and the rotor of the variocoupler is connected directly across the variable condenser, one terminal of which goes to the grid leak and condenser and from there to the grid of the tube. The other connection from the variable condenser goes to the plus filament lead of the A battery.

The plate lead of the tube goes to one side of the variometer and the other side of the variometer goes to one of the binding posts for the telephones. The other telephone binding post goes to the plus B battery and the minus B battery goes to the plus A battery. The plus A battery is hooked to the plus A of the tube socket and the minus A battery goes to the rheostat and the other side of the rheostat goes to the minus filament on the socket.

After I had completed this circuit I was trying it out in comparison with the neutrodyne circuit which we had here. First we would tune in on the neutrodyne circuit with, let us say, Pittsburgh, and then we shut off the neutrodyne and I picked up Pittsburgh with the small set. Then we tuned around and got WMAF, Round Hills, Mass., and then I got the same on the small set and we got Springfield on the neutrodyne and the same on the small set. We had New York City and then WCAP at Washington, D. C., on both sets. In fact, everything that we tuned in on the neutrodyne we brought in on the small set, but, of course, it was a great deal more trouble in getting it. We couldn't sit down as we do with the neutrodyne and just turn a dial and have the station come in. We had to fool and tune around here and there

the same as you do with any other regenerative circuit, but it proved the fact the sensitiveness of the circuit was there.

All you need is a little patience to bring it out. The carrier waves sounded like a canary bird shop. There were whistles everywhere and all we had to do was use a little patience to bring down these stations to where they were audible.

The "N" tube is a wonderful detector and a wonderful radio frequency amplifier. The sockets for these tubes sell for one dollar and the tube sells for seven dollars.

I do not know how many places in the United States this tube is purchasable now, but if any of you radio fans wish to have this tube and know it the way I know it, either Mr. Neely or I will be glad to buy it for you if you will send a money order.

I am now fixing up a five-stage radio frequency set with these tubes, and I'll tell you about it as soon as I can.

Erla Three-Tube Reflex Circuit

(Continued from Page 41)

these transformers have to be in the relations that I have said; otherwise the circuit will not work. A great number of people will probably think that there is no difference between reflex transformer number one and reflex transformer number two, but there is. To get the best results, or, in fact, to get any results at all with this circuit, it is absolutely impossible to switch these transformers around.

Across the primary binding posts of the first audio frequency transformer

(Continued on Page 46)

STATEMENT OF THE OWNERSHIP, MANAGEMENT, CIRCULATION, ETC.

Required by the Act of Congress of August 24, 1912

RADIO IN THE HOME

Published monthly at Philadelphia, Penna. FOR OCTOBER 1, 1923

State of Pennsylvania, County of Philadelphia. Before me, a Notary Public in and for the State and county aforesaid, personally appeared Henry M. Neely, who, having been duly sworn according to the law, deposes and says that he is the Editor of the RADIO IN THE HOME, and that the following is, to the best of his knowledge and belief, a true statement of the ownership, management, etc., of the aforesaid publication for the date shown in above caption.

1. That the names and addresses of the publisher, editor, managing editor and business managers are: Publisher—Henry M. Neely Publishing Company, 808 Chestnut Street, Phila., Pa.; Editor—Henry M. Neely, Delanco, N. J.; Managing Editor—Henry M. Neely, Delanco, N. J.; General Representative—Franklin N. Supplee, 2030 Race Street, Phila., Pa.
2. That the owner is: (If the publication is owned by an individual his name and address, or if owned by more than one individual the name of each, should be given below; if the publication is owned by a corporation the name of the corporation and the names and addresses of the stockholder owning or holding one per cent or more of the total amount of stock should be given.) Henry M. Neely Publishing Company, 608 Chestnut Street, Phila., Pa.; Henry M. Neely, Delanco, N. J.; John C. Martin, Wyncote, Pa.; Geo. W. Kraft, Jr., 5008 Larchwood Ave., Phila., Pa.; Franklin N. Supplee, 2030 Race Street, Phila., Pa.; Norman Neely, Delanco, N. J.
3. That the known bondholders, mortgages, and other security holders owning or holding one per cent or more of total amount of bonds, mortgages or other securities are: (If there are none, so state.) None.
4. That the two paragraphs next above, giving the names of the owners, stockholders and security holders, if any, contain not only the list of stockholders and security holders as they appear upon the books of the company, but also, in cases where the stockholders or security holder appears upon the books of the company as trustee or in any other fiduciary relation, the name of the person or corporation for whom such trustee is acting, is given; also that the said two paragraphs contain statements embracing affiant's full knowledge and belief as to the circumstances and conditions under which stockholders and security holders who do not appear upon the books of the belief as to the circumstances and conditions under which stockholders and security holders who do not appear upon the books of the company as trustees, hold stock and securities in a capacity other than that of a bona fide owner; and this affiant has no reason to believe that any other person, association or corporation has any interest direct or indirect in the said stock, bonds, or other securities than as so stated by him.

HENRY M. NEELY, Editor.
Sworn to and subscribed before me this 27th day of September, 1923.
(Seal) CHARLES E. JOHNSON.
(My commission expires January 7, 1927.)



Natural Re-PRODUCTION Atlas AMPLITONE LOUD SPEAKER

LIST PRICE \$25

Trade Mark

ALL of the program, natural as the original, re-PRODUCED on the Atlas Loud Speaker. Faithfully responsive, not to just one small range of sound intensity, but to the full scale of tone harmonics. The patented "double diaphragm"—triumph of the radio and acoustic sciences—automatically accommodates itself to every pitch. Blast and distortion are entirely eliminated. The patented "double diaphragm" is adjustable to operate most efficiently with individual receiving conditions. Ask the nearest Atlas dealer for a demonstration. Hear the difference this great innovation makes.

Letters From Users Requested

The remarkable re-PRODUCTIONS of the Atlas Loud Speaker make every owner enthusiastic. "Musical experts," writes a man in St. Paul, "have pronounced it the clearest reproduction they have ever heard." What results have you accomplished with your Atlas Loud Speaker? Write us about them—TODAY!

Write for Booklet "M"

Contains a great deal of helpful information.

Sole Canadian Distributors

THE MARCONI WIRELESS TELEGRAPH COMPANY OF CANADA, LIMITED
Montreal, Canada

Multiple Electric Products Co. Inc.

ORANGE ST. RADIO DIVISION NEWARK, N. J.



Long Distance ON THE New Crystal

FOR satisfactory radio reception, when a hook-up including a crystal is used, you want a crystal that is highly sensitive over its entire surface. The day is past when radio fans are content to hunt for spots. You want instant live contact. You want clear, loud reception with a crystal that will deliver to the ear phones 100% of the energy your aerial picks up. You also need a properly designed cat-whisker—one that will put as much or as little pressure on the crystal as you require. Efficiency in a crystal is often more a question of contact than of spot.

MULTI-POINT HIGH POWER CRYSTALS

are so perfect that they may be used to TEST your set

If your reception is not satisfactory with Multi-Point—look elsewhere for something to be improved—crystal, ground, coil or phones.

Price sixty cents each
or two for one dollar

By mail or at leading dealers.

To purchasers of our crystals we will supply a scientific cat-whisker, arm and post, complete—unmounted for
TWENTY CENTS EXTRA

Write your name and address on a card and wrap a dollar bill around it. Mail to us and we will send you two specimens, tested crystals.

If you include twenty cents in coin or stamps you will receive the scientific cat-whisker which you can mount in a few minutes.

If after three days' trial you want your money back—return the goods and a check for the full amount will go to you at once.

Circular on Request

We are a long distance ahead of the procession with our crystal. We are also just as far ahead with our new

UNGER CRYSTAL SET

described elsewhere in this magazine. This is equipped with a Multi-Point H. P. Crystal, and sells for

**\$7.50 by Mail,
Postage Prepaid**

A year's subscription for
RADIO IN THE HOME
is included in this price—which you can present to a friend if you are already a subscriber.

Sold by Leading Dealers

ADDRESS

**MULTI-POINT H. P. CO.
Box 4062
WEST PHILA., PA.**

*Especially Good
For Reflex
Ask Neely*

Radio Is Now a Billion Dollar Business

(Continued From Page 43)

for centuries. Home is where you are and what you make it, and all this expense that has been spoken of is for radio in the home.

But there are other places than just the home in which radio has its great part; they might be named briefly as follows: Hospitals, factories, schools, churches, offices, hotels, camps, stores, jails. Radio is transcontinental, international and worldwide in its scope. But to gather the basic facts of it and to depict them properly is a great task—Mr. Neely's task.

There will be no sudden changes in radio, but it will be a steady unfolding. I hope that these five plus six months may develop into many years of study, and from time to time I may have the privilege of asking you to go along with me on my trips, because I sincerely treasure the acquaintance and friendship of these men of mighty minds and great abilities and leaders of our country's destinies, because they teach me that radio is safe. They point out to me that if in two years there has been \$100,000,000 spent in broadcasting apparatus which it has cost \$30,000,000 to operate, and if there has been \$100,000,000 spent in radio receiving apparatus, what has the next twenty or thirty or fifty years in store for not only the American public, but the world in general?

WTAM, of Cleveland, Makes Its Debut

(Continued From Page 23)

Ample opportunity will be provided for the company to prove the efficiency of its radio batteries in this station.

It so happens that the Willard Company has recently introduced to broadcasting stations a new and specially designed battery for broadcasting purposes. For many months the company carefully studied the transmitting problems of the largest broadcasting stations in the country, finally evolving the new broadcasting battery which has a number of improved qualities, including constant voltage and great capacity.

It is this new type of broadcasting battery with which Willard's new broadcasting station is equipped. And its power for transmission depends on storage batteries alone, no motor generator being used. Through the use of storage batteries, to supply the 2500 volts required by the 1000-watt transmitter, this station bids fair to be the most quiet broadcasting station in the country, as every possible precaution has been taken to prevent interference from any source.

Two Stage Amplifier Unit

(Continued from Page 15)

you use them on the front of your panel or not. These binding posts have rubber caps and this is a great advantage, as it is almost impossible for a battery wire connection to come off and touch the metallic part of any other battery binding post to cause a short circuit.

In connecting this unit to your present set, you simply run wires from the telephone posts on your detector unit to the binding posts shown on the left hand side of this outfit, provided the phones on your detector are connected to the plus or positive side of your detector B battery. If not, change them to the plus side. You can leave your loud speaker permanently connected to the two binding posts on the right hand side and tune in with your phones in the second jack. As soon as you withdraw the phones from this jack the signals automatically transfer to the loud speaker.

The Gibbons With a Variocoupler

(Continued From Page 33)

but was very "broad" in its tuning and he was unable to separate two stations that were comparatively close together in wave length. He accordingly asked me whether it would not be possible to leave all of the instruments exactly as they were on the panel and baseboard and simply rewire it into this so-called Gibbons hookup.

We took his set out to station 3XP at Delanco and it just happened that Ted Vollten and I had been experimenting with this Gibbons hookup with a variocoupler and without a potentiometer such as was shown in the August issue. So we took Mr. Kraft's set and hooked it up in the new way to make it conform to the Gibbons circuit.

This, by the way, is not really a Gibbons circuit; it is merely an adaptation of one of the early hookups known as the DeForest ultra-audio circuit. But as it was put out by a man named Gibbons in its present form, he is certainly entitled to some credit for its adaptation to modern needs.

If you will compare the photographs of the set shown with this article with those shown in the June article on the single circuit, you will find that they are exactly the same. We did for Mr. Kraft just exactly what very many hundreds of possessors of the single circuit will want to do. We did not even move any of his instruments from the panel or baseboard nor did we make it necessary for him to get any other instruments. We took exactly what he had in a single circuit hookup, disconnected the wires in the detector circuit and reconnected them, leaving the wiring of the two stages of audio frequency amplification exactly as they had been before.

It is not necessary for me to give any detailed instructions further than the two diagrams and the photographs which you have here. This change can be made in any of the so-called single-circuit hookups even in the RC sets which have been so widely sold on the market at cut prices recently. These RC sets were very efficient in their day when extremely fine tuning was not necessary, but with the new wave lengths they have not proved so satisfactory as they were before. They were a very fine "buy" at the price at which they have been recently offered in large lots, but in many sections of the country they are not giving all of the satisfaction that they might give.

If you will look your RC sets over you will find that they are really single-circuit regenerative sets and you can easily adjust them to this Gibbons hookup and make sharp tuning sets of them and get very much more satisfaction from them than you will with the original hookup.

Erla Three-Tube Reflex Circuit

(Continued From Page 45)

there is a .001 mica condenser and across the minus filament wire and the wire that leads from the grid post of the second radio frequency reflex transformer there is a .002 mica condenser.

In wiring this circuit it is advisable for you to use a heavy wire, such as size No. 12 B. & S. gauge, either bare copper or tinned. It is not necessary for you to use a spaghetti covering with this circuit, and I would not advise you to do so because if you do you will have a tendency to run your wires too close together and by so doing you will probably have trouble with "capacity" in your leads. If you use the bare wire you will take pains in spacing the wires.

SILVERTONE Crystal Detector (Patent Pending)



\$1.50

NO CORROSIONS

Tested and Set by Actual Broadcast Music

ALWAYS SET AND READY

Adjustable—Demountable

Far superior by actual test for REFLEX CIRCUIT

Non-breakable top. Fully guaranteed. Adaptable to any standard mounted crystal.

The SILVERTONE was made and designed to meet the requirements for the amplification circuit and all circuits requiring

A DETECTOR OF THE BETTER KIND

On sale by all department stores and better-class radio dealers or remit price direct with your dealer's name.

SILVERTONE CRYSTAL CO.

5307 North 12th St.

Philadelphia

To a few high- grade Radio Manufacturers

¶ We would like to meet two or three manufacturers of high-grade receiving apparatus and to place before them our ideas on successful Radio Advertising.

¶ This organization talks your "language" and the "language" of hundreds of thousands of "radio-bugs" who buy and operate receiving apparatus.

¶ We "know" the radio-fan, whether he tunes in from the home of WEAJ or that of KHJ. We know radio—radio apparatus and radio technicalities when necessary. We know radio first hand.

¶ We invite correspondence and appointments from interested manufacturers. Inquiries entail no obligation.

**BERTRAM MAY
ADVERTISING**
1520 Chestnut St. Philadelphia.

**YOU TOO!
CAN EARN**

A Complete
**OUTFIT
LOOKE THIS**



Rodman L. Innes, of Primos, Pennsylvania

It doesn't matter what you want in Radio—from a switchpoint to a six-tube set with a loud speaker—

You Can Earn It

Dozens of men, women and boys are doing it by the attractive plan that we have developed.

Women's Clubs, High School Clubs, Fire Companies, Social Organizations—all are registering with us and working to get the

Best Outfits Money Can Buy

And without one cent of cost to them

WHAT DO YOU WANT IN RADIO ?
A CRYSTAL SET
A VARIOCOUPLER
A VARIABLE CONDENSER
TUBES
BATTERIES
HEAD PHONES

Write to me and I will tell you how to get it with no cost at all to you.

THE CIRCULATION MANAGER
RADIO IN THE HOME

608 CHESTNUT STREET

PHILADELPHIA, PA.

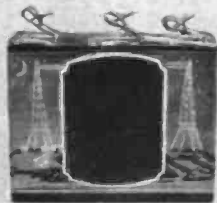
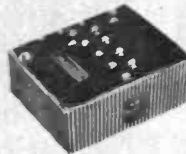
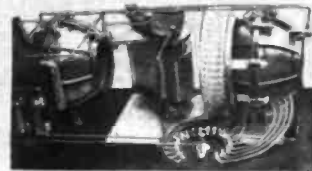
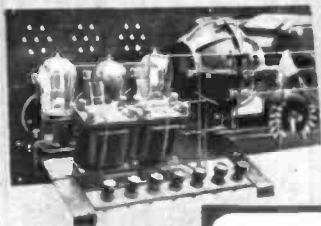

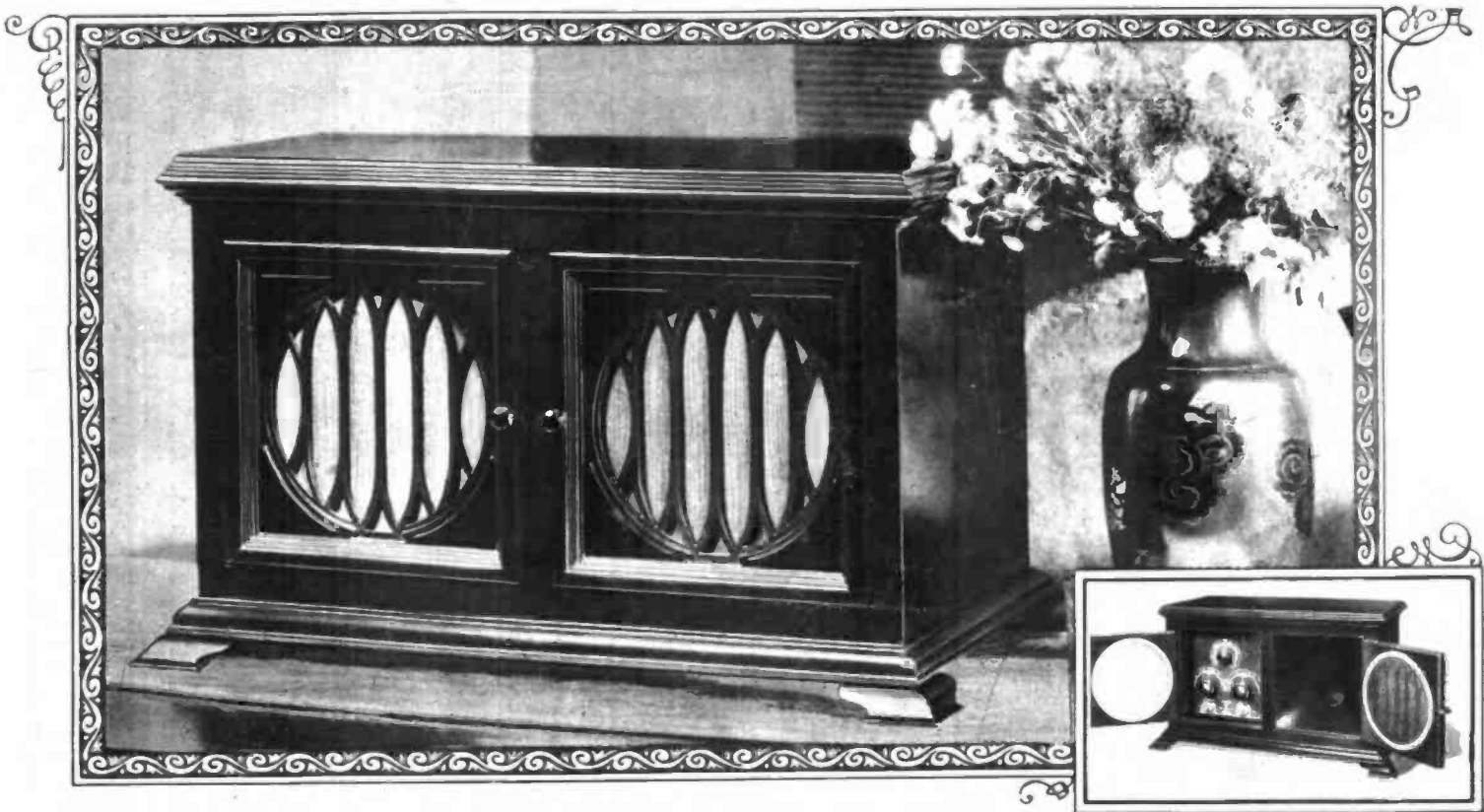

Opera from the Stage—Football from the Field with a **Radiola IV**

REG. U. S. PAT. OFF.

Radiola IV.

A long distance receiver made with the perfection for which RCA is famous. Mahogany finished cabinet; with four tubes (one spare); head phones and plug; silk covered wires. \$275 At the nearest radio or electrical dealer.



This Symbol of quality is your protection

Tune in—then shut the doors. Sit back and listen to the music that's being sung a hundred miles away. Dance to fine orchestras playing in the big cities. Call in the crowd when the big game is on. It's real!

Enclosed in its fine cabinet—with all its workings hidden—with its batteries inside—and its loudspeaker built-in—Radiola IV is a great achievement.

Simple, powerful, dependable. Not only by virtue of its radio construction, but by the perfection of its workmanship and finish. It gets distance—gets it simply and clearly, at the turn of a knob. And fits with dignity into the finest living room. Tune in—the air is crowded! Fun — music — education — big, exciting events. Listen in on them all with a Radiola IV.

Send for the free booklet that describes every Radiola

Radio Corporation of America

Sales Department
233 Broadway, New York

District Sales Offices
10 So. LaSalle St., Chicago, Ill. 433 California St., San Francisco, Cal.

RADIO CORPORATION OF AMERICA
Dept. 2098. (Address office nearest you.)
Please send me your free Radio Booklet.

Name _____
Street Address _____
City _____ R. F. D. _____
State _____

Radiola

REG. U. S. PAT. OFF.